

## 8-BIT SINGLE-CHIP MICROCONTROLLERS

The  $\mu$ PD789121A, 789122A, and 789124A ( $\mu$ PD78912xA hereafter) are  $\mu$ PD789124A Subseries products of the 78K/0S Series. The  $\mu$ PD789131A, 789132A, and 789134A ( $\mu$ PD78913xA hereafter) are  $\mu$ PD789134A Subseries products of the 78K/0S Series.

Besides an 8-bit CPU, these microcontrollers incorporate a variety of hardware such as I/O ports, timers, a serial interface, A/D converters, and interrupt control.

A stricter quality assurance program (called special grade in NEC's grade classification) is applied to the  $\mu$ PD789121A(A), 789122A(A), 789124A(A) ( $\mu$ PD78912xA(A) hereafter), and  $\mu$ PD789131A(A), 789132A(A), 789134A(A) ( $\mu$ PD78913xA(A) hereafter), compared to the  $\mu$ PD78912xA and 78913xA, which are classified as standard grade.

In addition, a flash memory version ( $\mu$ PD78F9136A) that can operate within the same power supply voltage range as the mask ROM version, and a range of development tools are also being prepared.

**Detailed function descriptions are provided in the following user's manuals. Be sure to read them before designing.**

**$\mu$ PD789104A, 789114A, 789124A, 789134A Subseries User's Manual: To be prepared**  
**78K/0S Series User's Manual Instruction: U11047E**

### FEATURES

- On-chip multiplier: 8 bits  $\times$  8 bits = 16 bits
- ROM and RAM sizes

Part Number	Item	Program Memory (ROM)	Data Memory (Internal High-Speed RAM)	Package
$\mu$ PD789121A, 789131A, 789121A(A), 789131A(A)		2 Kbytes	256 bytes	30-pin plastic SSOP (7.62 mm (300))
$\mu$ PD789122A, 789132A, 789122A(A), 789132A(A)		4 Kbytes		
$\mu$ PD789124A, 789134A, 789124A(A), 789134A(A)		8 Kbytes		

- Built-in RC oscillator
- Minimum instruction execution time can be changed from high-speed (0.5  $\mu$ s) to low-speed (2.0  $\mu$ s) (@ 4.0-MHz operation with system clock)
- I/O ports: 20
- Serial interface: 1 channel: Switchable between 3-wire serial I/O and UART modes
- 8-bit resolution A/D converter: 4 channels ( $\mu$ PD78912xA, 78912xA(A))
- 10-bit resolution A/D converter: 4 channels ( $\mu$ PD78913xA, 78913xA(A))
- Timers: 3 channels
  - 16-bit timer: 1 channel
  - 8-bit timer/event counter: 1 channel
  - Watchdog timer: 1 channel
- Power supply voltage:  $V_{DD} = 1.8$  to 5.5 V

The information in this document is subject to change without notice. Before using this document, please confirm that this is the latest version.  
 Not all devices/types available in every country. Please check with local NEC representative for availability and additional information.

**APPLICATIONS**

Cleaners, washing machines, and refrigerators

**ORDERING INFORMATION**

Part Number	Package	Quality grade
$\mu$ PD789121AMC-xxx-5A4	30-pin plastic SSOP (7.62 mm (300))	Standard
$\mu$ PD789122AMC-xxx-5A4	30-pin plastic SSOP (7.62 mm (300))	Standard
$\mu$ PD789124AMC-xxx-5A4	30-pin plastic SSOP (7.62 mm (300))	Standard
$\mu$ PD789131AMC-xxx-5A4	30-pin plastic SSOP (7.62 mm (300))	Standard
$\mu$ PD789132AMC-xxx-5A4	30-pin plastic SSOP (7.62 mm (300))	Standard
$\mu$ PD789134AMC-xxx-5A4	30-pin plastic SSOP (7.62 mm (300))	Standard
$\mu$ PD789121AMC(A)-xxx-5A4	30-pin plastic SSOP (7.62 mm (300))	Special
$\mu$ PD789122AMC(A)-xxx-5A4	30-pin plastic SSOP (7.62 mm (300))	Special
$\mu$ PD789124AMC(A)-xxx-5A4	30-pin plastic SSOP (7.62 mm (300))	Special
$\mu$ PD789131AMC(A)-xxx-5A4	30-pin plastic SSOP (7.62 mm (300))	Special
$\mu$ PD789132AMC(A)-xxx-5A4	30-pin plastic SSOP (7.62 mm (300))	Special
$\mu$ PD789134AMC(A)-xxx-5A4	30-pin plastic SSOP (7.62 mm (300))	Special

**Remark** xxx indicates ROM code suffix.

Please refer to "Quality Grades on NEC Semiconductor Devices" (Document No. C11531E) published by NEC Corporation to know the specification of quality grade on the devices and its recommended applications.

**78K/0S SERIES LINEUP**

The products in the 78K/0S Series are listed below. The names enclosed in boxes are subseries names.

 Products under mass production

 Products under development

Y subseries supports SMB.

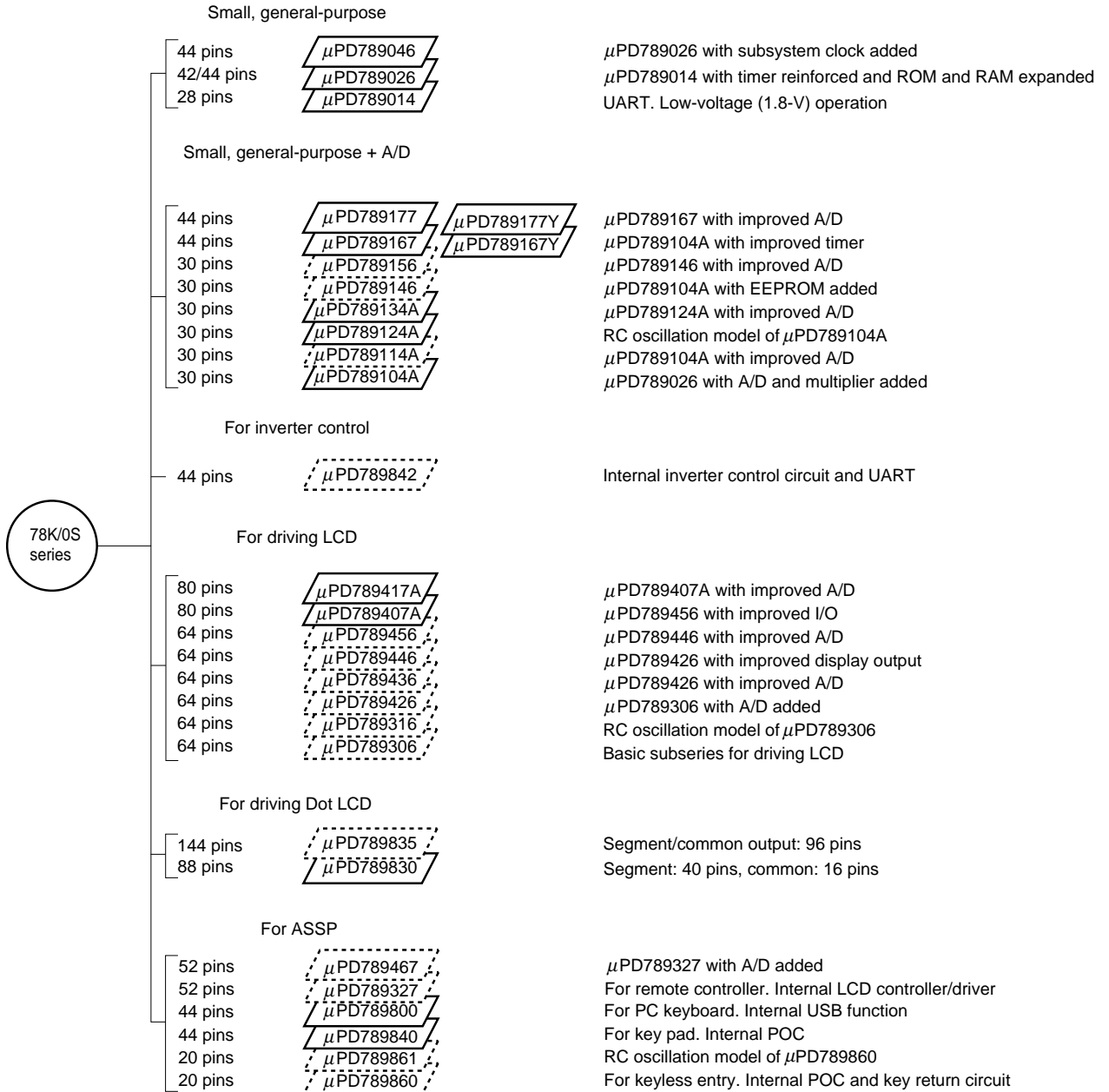

The major differences between subseries are shown below.

Function Subseries Name		ROM Capacity	Timer				8-bit A/D	10-bit A/D	Serial Interface	I/O	V <sub>DD</sub> MIN Value	Remark	
			8-bit	16-bit	Watch	WDT							
Small, general- purpose	μPD789046	16 K	1 ch	1 ch	1 ch	1 ch	–	–	1 ch (UART: 1 ch)	34 pins	1.8 V	–	
	μPD789026	4 K-16 K			–								
	μPD789014	2 K-4 K	2 ch	–						22 pins			
Small, general- purpose + A/D	μPD789177	16 K-24 K	3 ch	1 ch	1 ch	1 ch	–	8 ch	1 ch (UART: 1 ch)	31 pins	1.8 V	–	
	μPD789167						8 ch	–					
	μPD789156	8 K-16 K	1 ch	–	–	–	–	4 ch	20 pins			Internal EEPROM	
	μPD789146						4 ch	–					
	μPD789134A	2 K-8 K					–	4 ch					RC oscillation version
	μPD789124A						4 ch	–					
	μPD789114A						–	4 ch					
	μPD789104A						4 ch	–					
For inverter control	μPD789842	8 K-16 K	3 ch	<b>Note</b>	1 ch	1 ch	8 ch	–	1 ch (UART: 1 ch)	30 pins	4.0 V	–	
For LCD driving	μPD789417A	12 K-24 K	3 ch	1 ch	1 ch	1 ch	–	7 ch	1 ch (UART: 1 ch)	43 pins	1.8 V	–	
	μPD789407A						7 ch	–					
	μPD789456	12 K-16 K	2 ch				–	6 ch		30 pins			
	μPD789446						6 ch	–					
	μPD789436						–	6 ch		40 pins			
	μPD789426						6 ch	–					
	μPD789316	8 K to 16K					–	–	2 ch (UART: 1 ch)	23 pins			RC oscillation version
	μPD789306						–	–					
For Dot LCD driving	μPD789835	24 K-60 K	6 ch	–	1 ch	1 ch	2 ch	–	1 ch	27 pins	1.8 V	–	
	μPD789830	24 K	1 ch	1 ch			–	–	1 ch (UART: 1 ch)	30 pins	2.7 V		
ASSP	μPD789467	4 K-24 K	2 ch	–	1 ch	1 ch	1 ch	–	–	18 pins	1.8 V	Internal LCD	
	μPD789327						–		1 ch	21 pins			
	μPD789800	8 K	2 ch	1 ch	–	1 ch	–		2 ch (USB: 1 ch)	31 pins	4.0 V	–	
	μPD789840						4 ch		1 ch	29 pins	2.8 V		
	μPD789861	4 K					–		–	14 pins	1.8 V	RC oscillation version, Internal EEPROM	
	μPD789860						–			Internal EEPROM			

**Note** 10-bit timer: 1 channel

OVERVIEW OF FUNCTIONS

Item		μPD789121A μPD789131A μPD789121A(A) μPD789131A(A)	μPD789122A μPD789132A μPD789122A(A) μPD789132A(A)	μPD789124A μPD789134A μPD789124A(A) μPD789134A(A)
Internal memory	ROM	2 Kbytes	4 Kbytes	8 Kbytes
	High-speed RAM	256 bytes		
Oscillator		RC Oscillator		
Minimum instruction execution time		0.5/2.0 μs (@ 4.0-MHz operation with system clock)		
General-purpose registers		8 bits × 8 registers		
Instruction set		<ul style="list-style-type: none"> <li>• 16-bit operations</li> <li>• Bit manipulations (set, reset, and test)</li> </ul>		
Multiplier		8 bits × 8 bits = 16 bits		
I/O ports		Total: 20 <ul style="list-style-type: none"> <li>• CMOS input: 4</li> <li>• CMOS I/O: 12</li> <li>• N-ch open-drain (12-V withstand voltage): 4</li> </ul>		
A/D converters		<ul style="list-style-type: none"> <li>• 8-bit resolution × 4 channels (μPD78912xA, 78912xA(A))</li> <li>• 10-bit resolution × 4 channels (μPD78913xA, 78913xA(A))</li> </ul>		
Serial interface		<ul style="list-style-type: none"> <li>• Switchable between 3-wire serial I/O and UART modes</li> </ul>		
Timer		<ul style="list-style-type: none"> <li>• 16-bit timer: 1 channel</li> <li>• 8-bit timer/event counter: 1 channel</li> <li>• Watchdog timer: 1 channel</li> </ul>		
Timer output		1 output (16-bit/8-bit timer alternate function)		
Vectored interrupt sources	Maskable	Internal: 6, External: 3		
	Non-maskable	Internal: 1		
Power supply voltage		V <sub>DD</sub> = 1.8 to 5.5 V		
Operating ambient temperature		T <sub>A</sub> = -40 to +85°C		
Package		<ul style="list-style-type: none"> <li>• 30-pin plastic SSOP (7.62 mm (300))</li> </ul>		

**CONTENTS**

<b>1. PIN CONFIGURATION (TOP VIEW)</b> .....	<b>7</b>
<b>2. BLOCK DIAGRAM</b> .....	<b>8</b>
<b>3. PIN FUNCTIONS</b> .....	<b>9</b>
3.1 Port Pins.....	9
3.2 Non-Port Pins.....	10
3.3 Pin I/O Circuits and Recommended Connection of Unused Pins.....	11
<b>4. MEMORY SPACE</b> .....	<b>13</b>
<b>5. PERIPHERAL HARDWARE FUNCTIONS</b> .....	<b>14</b>
5.1 Ports .....	14
5.2 Clock Generator.....	14
5.3 Timer.....	15
5.4 A/D Converter .....	17
5.5 Serial Interface 20.....	18
5.6 Multiplier.....	19
<b>6. INTERRUPT FUNCTION</b> .....	<b>20</b>
<b>7. STANDBY FUNCTION</b> .....	<b>22</b>
<b>8. RESET FUNCTION</b> .....	<b>22</b>
<b>9. MASK OPTIONS</b> .....	<b>22</b>
<b>10. INSTRUCTION SET OVERVIEW</b> .....	<b>23</b>
10.1 Conventions.....	23
10.2 Operations.....	25
<b>11. ELECTRICAL SPECIFICATIONS</b> .....	<b>30</b>
<b>12. EXAMPLE OF RC OSCILLATOR FREQUENCY CHARACTERISTICS (REFERENCE VALUES)</b> .....	<b>41</b>
<b>13. PACKAGE DRAWING</b> .....	<b>43</b>
<b>14. RECOMMENDED SOLDERING CONDITIONS</b> .....	<b>44</b>
<b>APPENDIX A DEVELOPMENT TOOLS</b> .....	<b>45</b>
<b>APPENDIX B RELATED DOCUMENTS</b> .....	<b>47</b>

1. PIN CONFIGURATION (TOP VIEW)

- 30-pin plastic SSOP (7.62 mm (300))

μPD789121AMC-xxx-5A4      μPD789122AMC-xxx-5A4      μPD789124AMC-xxx-5A4  
 μPD789131AMC-xxx-5A4      μPD789132AMC-xxx-5A4      μPD789134AMC-xxx-5A4  
 μPD789121AMC(A)-xxx-5A4      μPD789122AMC(A)-xxx-5A4      μPD789124AMC(A)-xxx-5A4  
 μPD789131AMC(A)-xxx-5A4      μPD789132AMC(A)-xxx-5A4      μPD789134AMC(A)-xxx-5A4

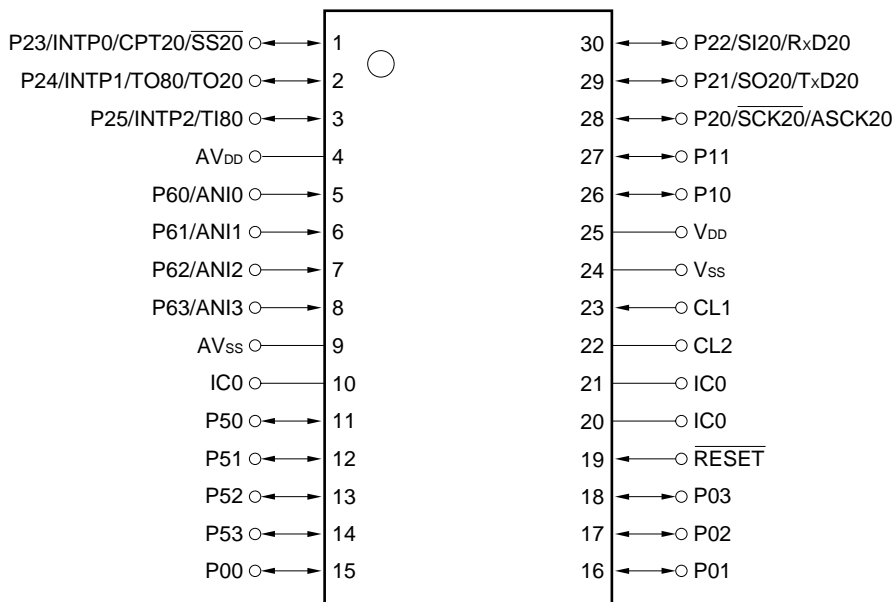

- Cautions**
1. Connect the IC0 (Internally Connected) pin directly to Vss.
  2. Connect the AVDD pin to VDD.
  3. Connect the AVSS pin to Vss.

ANI0 to ANI3:	Analog Input	P60 to P63:	Port6
ASCK20:	Asynchronous Serial Input	RESET:	Reset
AVDD:	Analog Power Supply	RxD20:	Receive Data
AVSS:	Analog Ground	SCK20:	Serial Clock Input/Output
CL1, CL2:	RC Oscillator	SI20:	Serial Data Input
CPT20:	Capture Trigger Input	SO20:	Serial Data Output
IC0:	Internally Connected	SS20:	Chip Select Input
INTP0 to INTP2:	Interrupt from Peripherals	TI80:	Timer Input
P00 to P03:	Port0	TO20, TO80:	Timer Output
P10, P11:	Port1	TxD20:	Transmit Data
P20 to P25:	Port2	VDD:	Power Supply
P50 to P53:	Port5	VSS:	Ground

2. BLOCK DIAGRAM

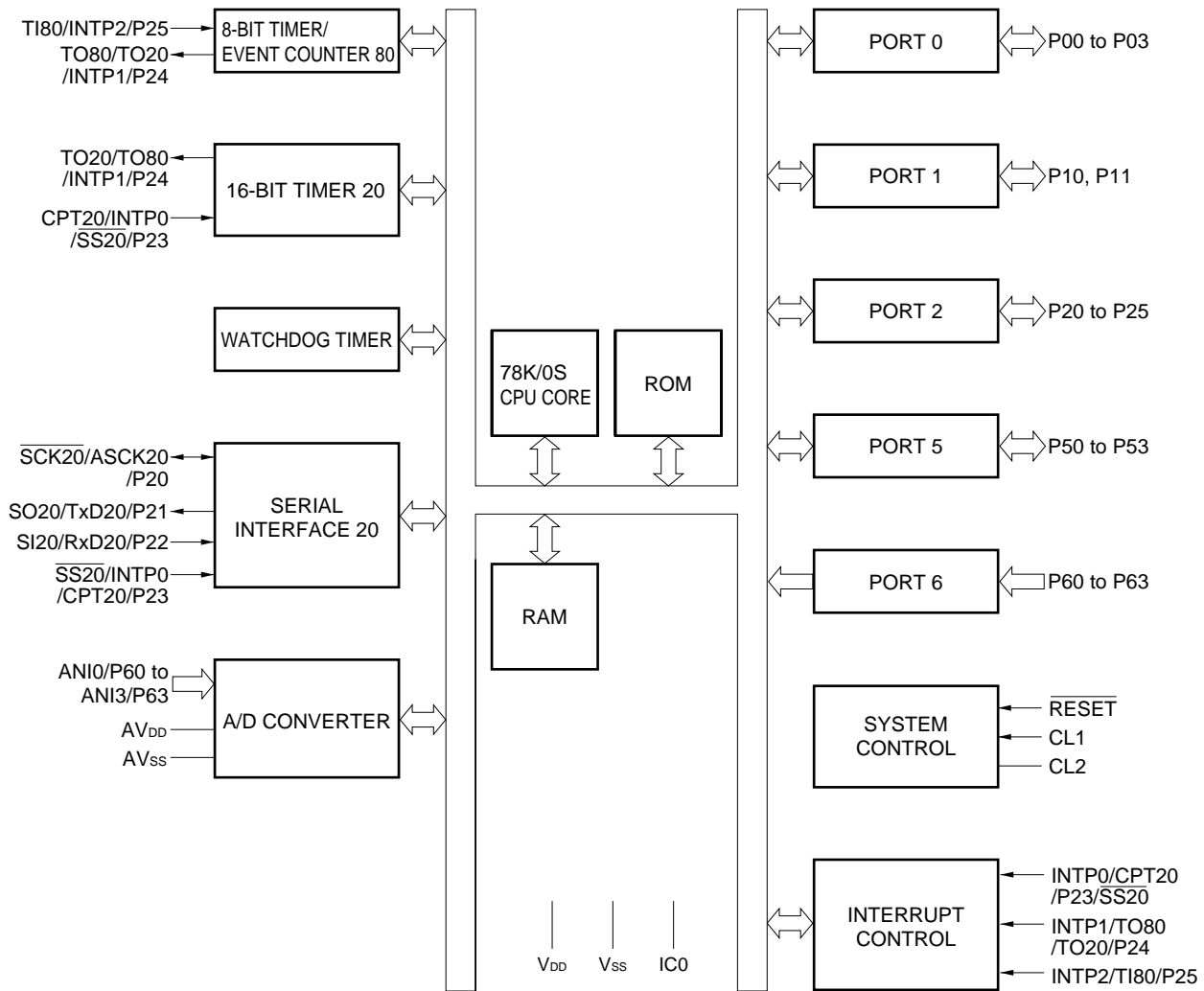

**Remark** The internal ROM capacity varies depending on the product.



### 3. PIN FUNCTIONS

#### 3.1 Port Pins

Pin Name	I/O	Function	After Reset	Alternate Function
P00 to P03	I/O	Port 0 4-bit input/output port Input/output can be specified in 1-bit units When used as an input port, an on-chip pull-up resistor can be specified by means of software.	Input	–
P10, P11	I/O	Port 1 2-bit input/output port Input/output can be specified in 1-bit units When used as an input port, an on-chip pull-up resistor can be specified by means of software.	Input	–
P20	I/O	Port 2 6-bit input/output port Input/output can be specified in 1-bit units When used as an input port, an on-chip pull-up resistor can be specified by means of software.	Input	$\overline{\text{SCK20}}/\text{ASCK20}$
P21				SO20/TxD20
P22				SI20/RxD20
P23				$\overline{\text{INTP0}}/\text{CPT20}$ $\overline{\text{SS20}}$
P24				$\overline{\text{INTP1}}/\text{TO80}/\text{TO20}$
P25				INTP2/TI80
P50 to P53	I/O	Port 5 4-bit N-ch open-drain input/output port Input/output can be specified in 1-bit units An on-chip pull-up resistor can be specified by the mask option.	Input	–
P60 to P63	Input	Port 6 4-bit input-only port	Input	ANI0 to ANI3

3.2 Non-Port Pins

Pin Name	I/O	Function	After Reset	Alternate Function
INTP0	Input	External interrupt request input for which the valid edge (rising edge, falling edge, or both rising and falling edges) can be specified	Input	P23/CPT20/SS20
INTP1				P24/TO80/TO20
INTP2				P25/TI80
SI20	Input	Serial interface serial data input	Input	P22/RxD20
SO20	Output	Serial interface serial data output	Input	P21/TxD20
SCK20	I/O	Serial interface serial clock input/output	Input	P20/ASCK20
ASCK20	Input	Serial clock input for asynchronous serial interface	Input	P20/SCK20
SS20	Input	Chip select input for serial interface	Input	P23/CPT20/INTP0
RxD20	Input	Serial data input for asynchronous serial interface	Input	P22/SI20
TxD20	Output	Serial data output for asynchronous serial interface	Input	P21/SO20
TI80	Input	External count clock input to 8-bit timer/event counter 80	Input	P25/INTP2
TO80	Output	8-bit timer/event counter 80 output	Input	P24/INTP1/TO20
TO20	Output	16-bit timer 20 output	Input	P24/INTP1/TO80
CPT20	Input	Capture edge input	Input	P23/INTP0/SS20
ANI0 to ANI3	Input	A/D converter analog input	Input	P60 to P63
AV <sub>DD</sub>	-	A/D converter analog power supply	-	-
AV <sub>SS</sub>	-	A/D converter ground potential	-	-
CL1	Input	Connected to resistor (R) or capacitor (C)	-	-
CL2	-		-	-
RESET	Input	System reset input	Input	-
V <sub>DD</sub>	-	Positive power supply	-	-
V <sub>SS</sub>	-	Ground potential	-	-
IC0	-	Internally connected. Connect directly to V <sub>SS</sub> .	-	-

### 3.3 Pin I/O Circuits and Recommended Connection of Unused Pins

The input/output circuit type of each pin and recommended connection of unused pins are shown in Table 3-1. For the input/output circuit configuration of each type, refer to Figure 3-1.

**Table 3-1. Types of Pin Input/Output Circuits**

Pin Name	Input/Output Circuit Type	I/O	Recommended Connection of Unused Pins
P00 to P03	5-A	I/O	Input: Independently connect to V <sub>DD</sub> or V <sub>SS</sub> via a resistor. Output: Leave open
P10, P11			
P20/SCK20/ASCK20	8-A		Input: Independently connect to V <sub>SS</sub> via a resistor. Output: Leave open
P21/SO20/TxD20			
P22/SI20/RxD20			
P23/INTP0/CPT20/SS20			
P24/INTP1/TO80/TO20			
P25/INTP2/TI80			
P50 to P53	13-W	Input: Independently connect to V <sub>DD</sub> via a resistor. Output: Leave open	
P60/ANI0 to P63/ANI3	9-C	Input	Connect directly to V <sub>DD</sub> or V <sub>SS</sub> .
AV <sub>DD</sub>	–	–	Connect to V <sub>DD</sub> .
AV <sub>SS</sub>	–	–	Connect to V <sub>SS</sub> .
RESET	2	Input	–
IC0	–	–	Connect directly to V <sub>SS</sub> .

Figure 3-1. Pin Input/Output Circuits

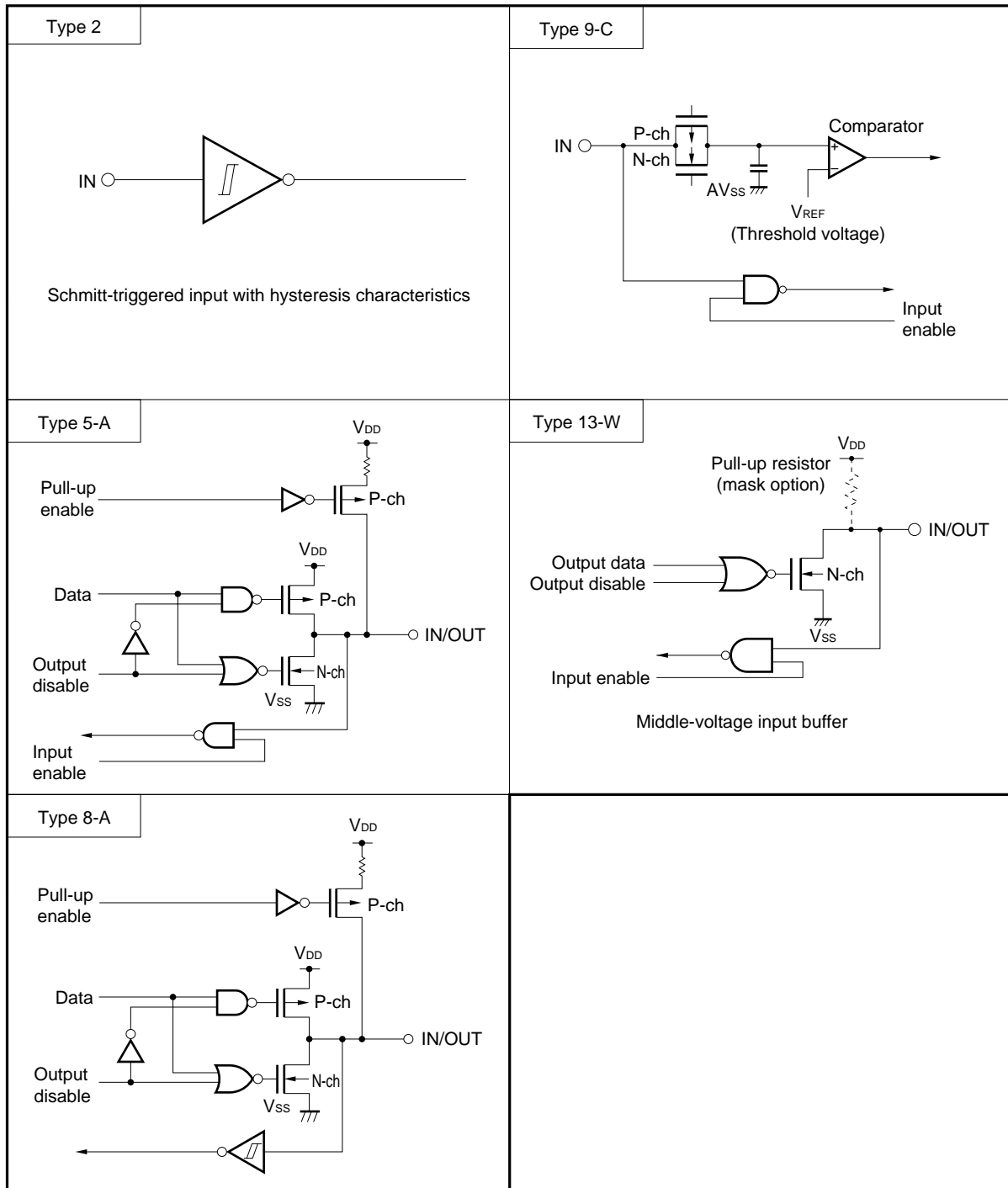

### 4. MEMORY SPACE

Figure 4-1 shows the memory map of the μPD78912xA, 78913xA, 78912xA(A), and 78913xA(A).

Figure 4-1. Memory Map

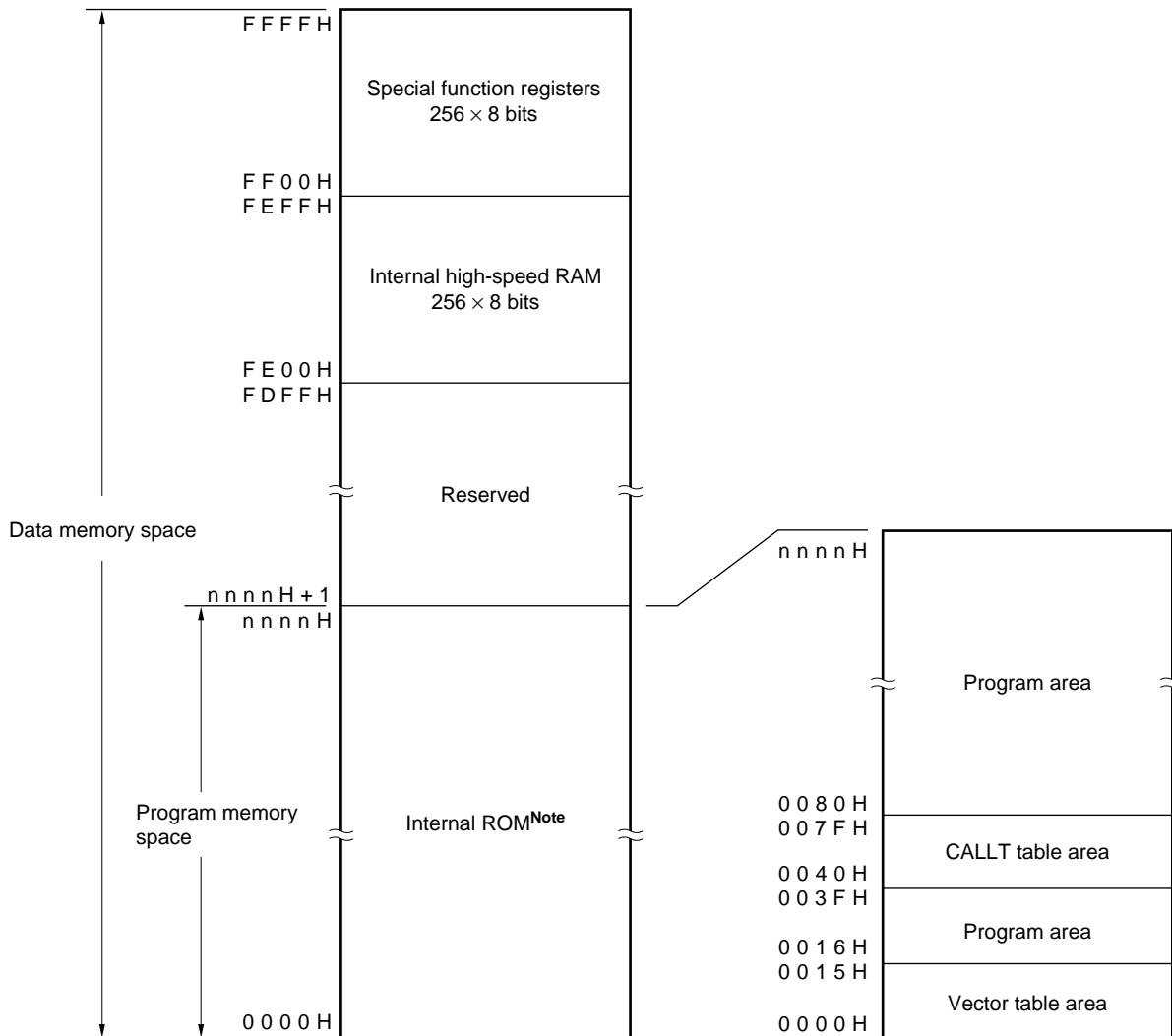

**Note** The internal ROM capacity depends on the product. (See the following table).

Part Number	Last Address of Internal ROM nnnnH
μPD789121A, 789131A, 789121A(A), 789131A(A)	07FFH
μPD789122A, 789132A, 789122A(A), 789132A(A)	0FFFH
μPD789124A, 789134A, 789124A(A), 789134A(A)	1FFFH

## 5. PERIPHERAL HARDWARE FUNCTIONS

### 5.1 Ports

The following three types of I/O ports are available:

• CMOS Input (port 6):	4
• CMOS input/output (ports 0 to 2):	12
• N-ch open-drain input/output (port 5):	4
<hr/>	
Total:	20

**Table 5-1. Port Functions**

Port Name	Pin Name	Function
Port 0	P00 to P03	Input/output port. Input/output can be specified in 1-bit units. When used as an input port, an on-chip pull-up resistor can be specified by means of software.
Port 1	P10, P11	Input/output port. Input/output can be specified in 1-bit units. When used as an input port, an on-chip pull-up resistor can be specified by means of software.
Port 2	P20 to P25	Input/output port. Input/output can be specified in 1-bit units. An on-chip pull-up resistor can be specified by means of software.
Port 5	P50 to P53	N-channel open-drain input/output port. Input/output can be specified in 1-bit units. An on-chip pull-up resistor can be specified by the mask option.
Port 6	P60 to P63	Input-only port

### 5.2 Clock Generator

An on-chip system clock generator is provided.  
The minimum instruction execution time can be changed.

- 0.5 μs/2.0 μs (@ 4.0-MHz operation with system clock)

**Figure 5-1. Clock Generator Block Diagram**

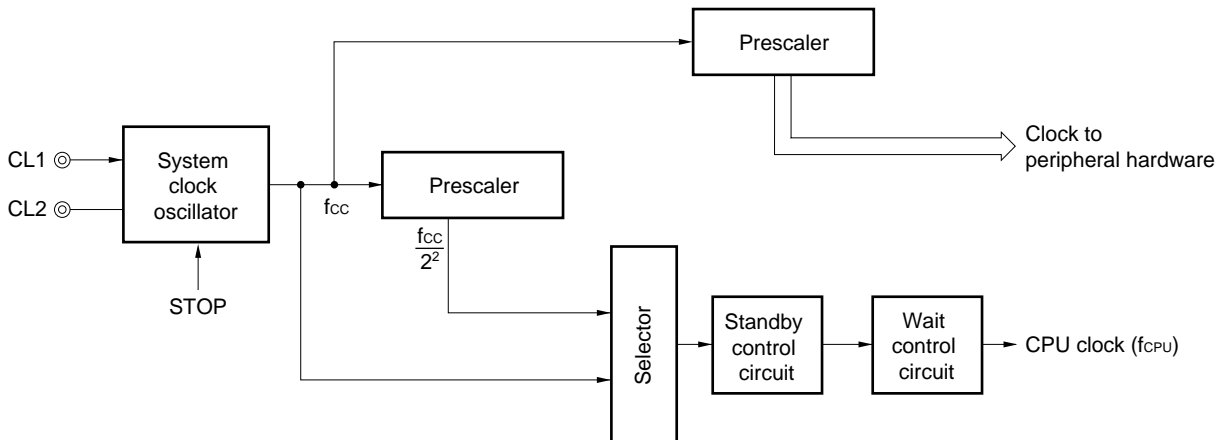

### 5.3 Timer

Three on-chip timers are provided.

- 16-bit timer 20: 1 channel
- 8-bit timer/event counter 80: 1 channel
- Watchdog timer: 1 channel

**Table 5-2. Timer Operation**

		16-Bit Timer 20	8-Bit Timer/Event Counter 80	Watchdog Timer
Operation mode	Interval timer	–	1 channel	1 channel
	External event counter	–	1 channel	–
Function	Timer output	1 output	1 output	–
	PWM output	–	1 output	–
	Square wave output	–	1 output	–
	Capture	1 input	–	–
	Interrupt request	1	1	1

**Figure 5-2. Block Diagram of 16-Bit Timer 20 (TM20)**

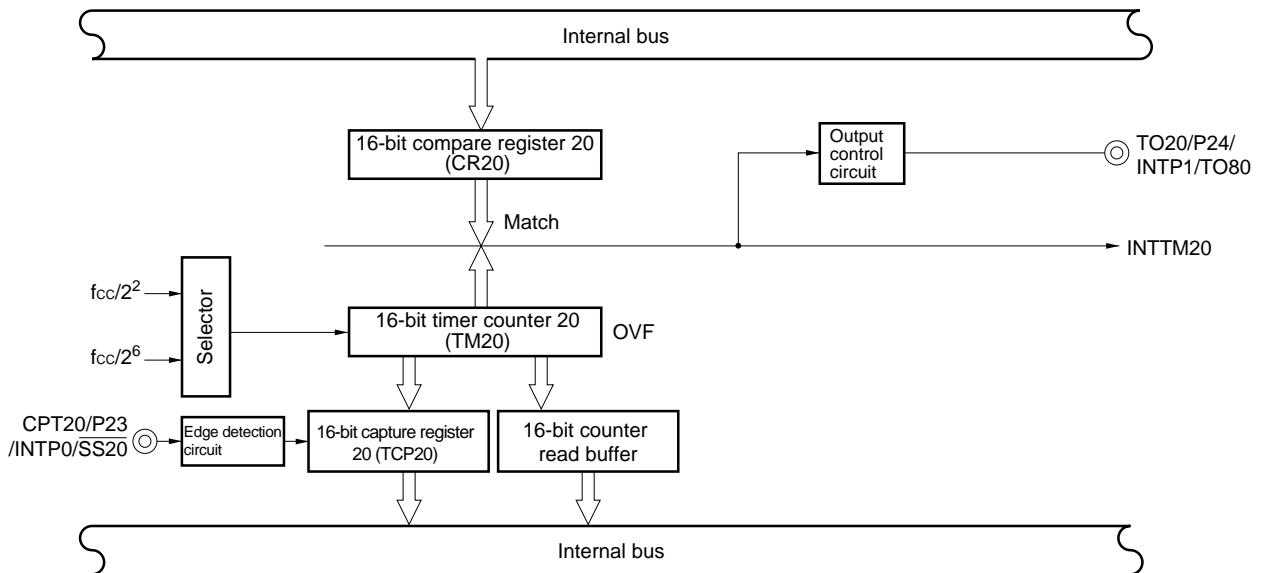

Figure 5-3. Block Diagram of 8-Bit Timer/Event Counter 80 (TM80)

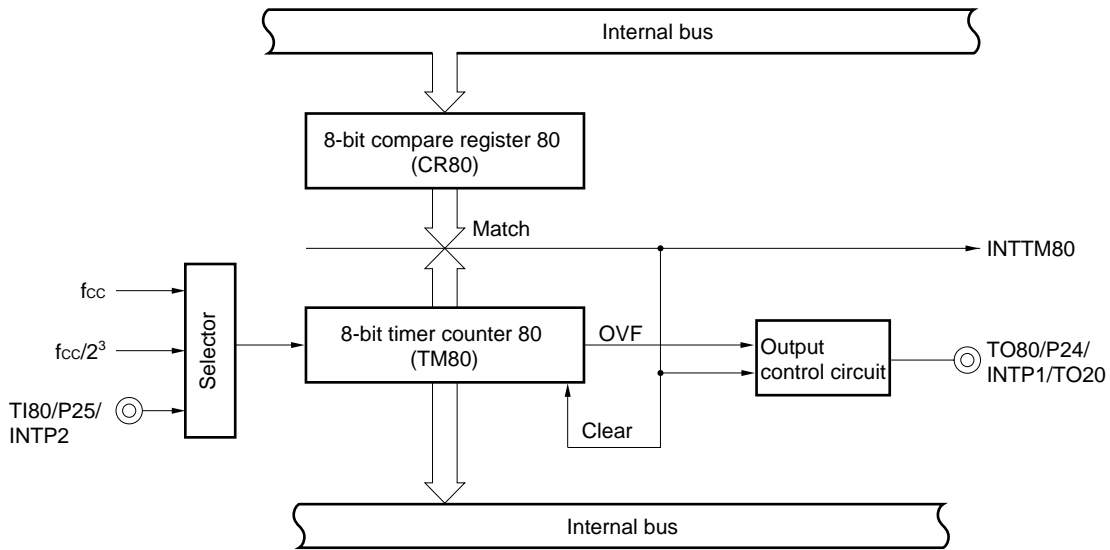
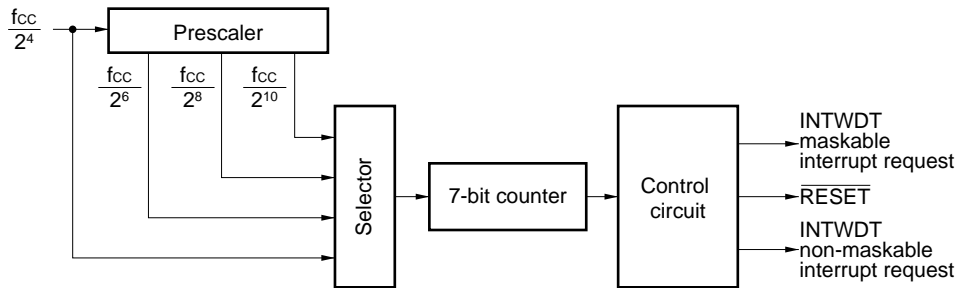

Figure 5-4. Watchdog Timer Block Diagram





### 5.4 A/D Converter

The conversion resolution of the A/D converter differs depending on the product as shown below.

- 8-bit A/D converter × 4 channels.... μPD789121A, 789122A, 789124A, 789121A(A), 789122A(A), 789124A(A)
- 10-bit A/D converter × 4 channels.. μPD789131A, 789132A, 789134A, 789131A(A), 789132A(A), 789134A(A)

A/D conversion can be only started by software.

**Figure 5-5. A/D Converter Block Diagram**

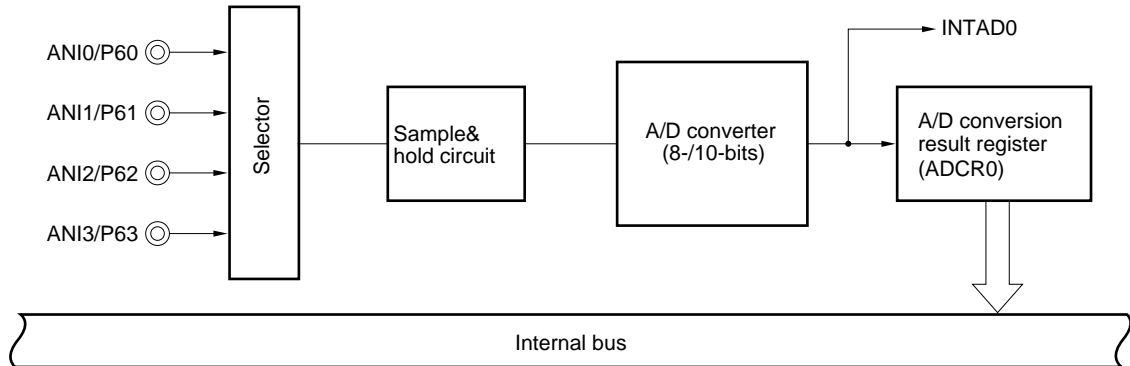

### 5.5 Serial Interface 20

A one-channel serial interface is incorporated.

Serial interface 20 has following three modes:

- Operation stop mode: Power consumption can be reduced.
- Asynchronous serial interface (UART) mode: A dedicated baud rate generator is incorporated.
- 3-wire serial I/O mode: A function to select the clock phase or data phase is incorporated.

Figure 5-6. Block Diagram of Serial Interface 20

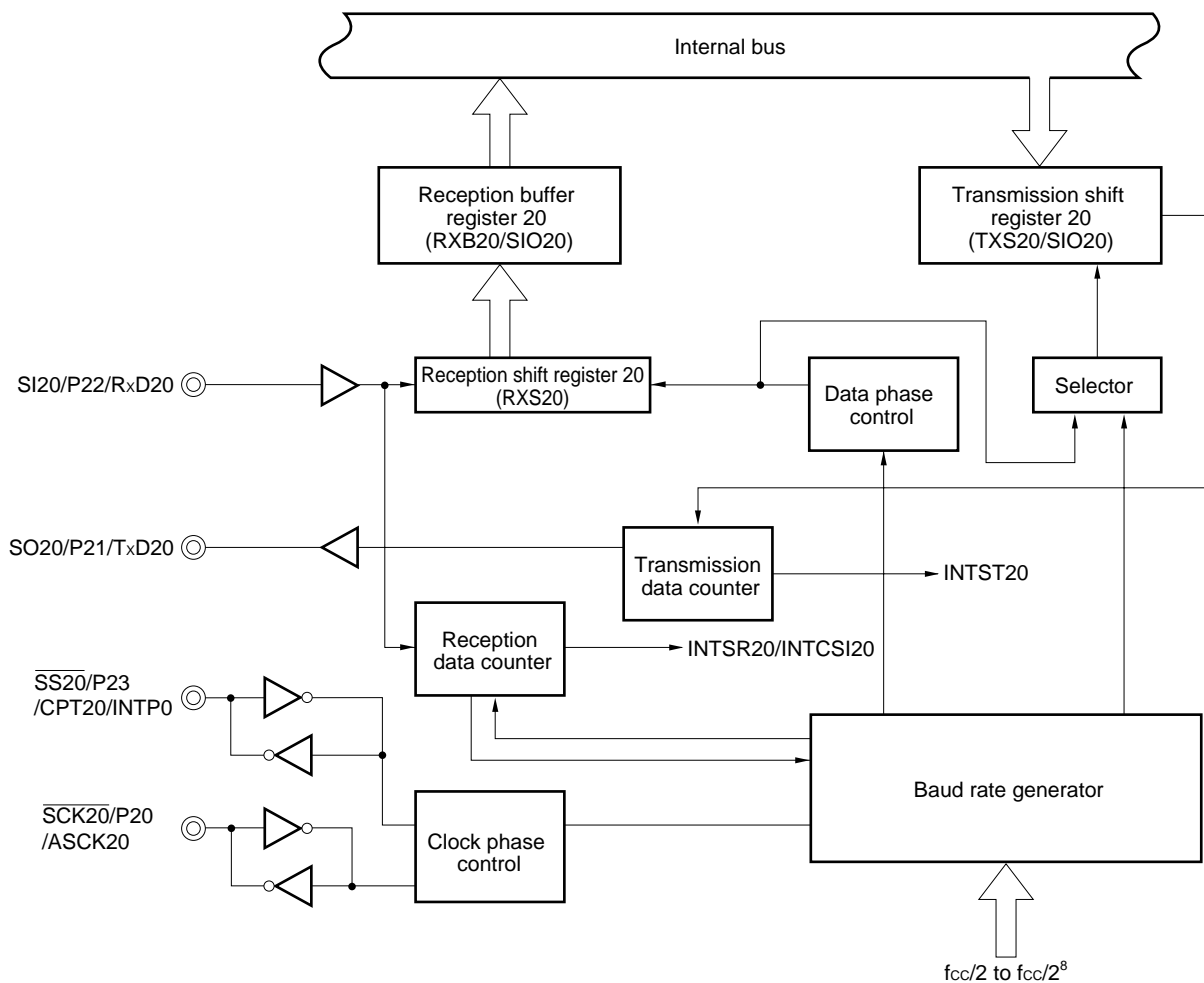

### 5.6 Multiplier

The calculation of 8 bits × 8 bits = 16 bits can be performed.

Figure 5-7. Multiplier Block Diagram

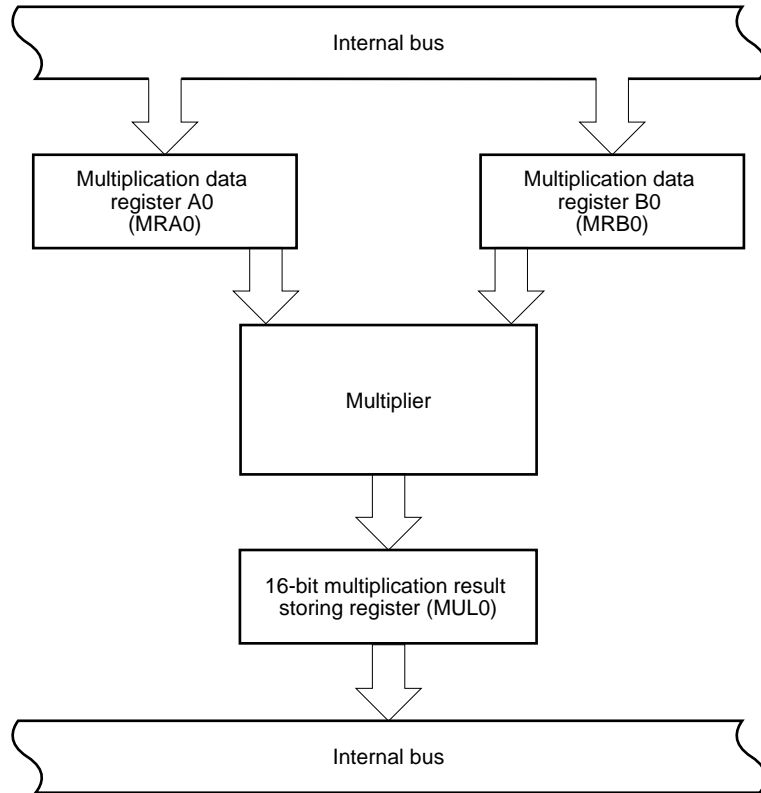

## 6. INTERRUPT FUNCTION

A total of 10 interrupt sources are provided, divided into the following two types.

- Non-maskable interrupts: 1 source
- Maskable interrupts: 9 sources

**Table 6-1. Interrupt Source List**

Interrupt Type	Priority <sup>Note 1</sup>	Interrupt Source		Internal/External	Vector Table Address	Basic Configuration Type <sup>Note 2</sup>
		Name	Trigger			
Non-maskable	–	INTWDT	Watchdog timer overflow (with watchdog timer mode 1 selected)	Internal	0004H	(A)
Maskable	0	INTWDT	Watchdog timer overflow (with the interval timer mode selected)			External
	1	INTP0	Pin input edge detection	(C)		
	2	INTP1				
	3	INTP2				
	4	INTSR20	End of serial interface 20 UART reception	Internal	000CH  000EH 0010H 0012H 0014H	(B)
		INTCSI20	End of serial interface 20 3-wire SIO transfer reception			
	5	INTST20	End of serial interface 20 UART transmission			
	6	INTTM80	Generation of matching signal of 8-bit timer/event counter 80			
7	INTTM20	Generation of matching signal of 16-bit timer 20				
8	INTAD0	A/D conversion completion signal				

**Notes** 1. Priority is the priority order when several maskable interrupt requests are generated at the same time. 0 is the highest order and 8 is the lowest order.

2. Basic configuration types (A), (B), and (C) correspond to (A), (B), and (C) in Figure 6-1.

**Remark** As the interrupt source of the watchdog timer (INTWDT), either a non-maskable interrupt or a maskable interrupt (internal) can be selected.

Figure 6-1. Basic Configuration of Interrupt Function

(A) Internal non-maskable interrupt

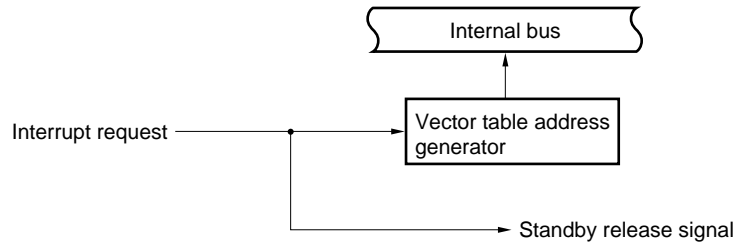

(B) Internal maskable interrupt

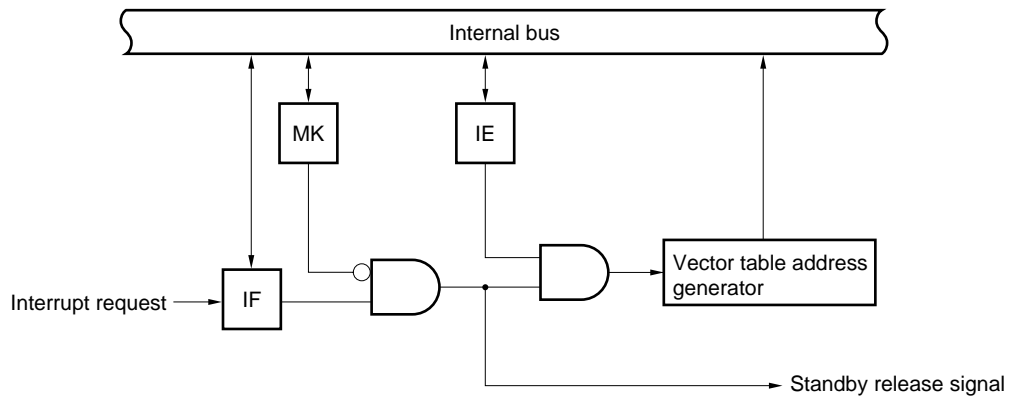

(C) External maskable interrupt

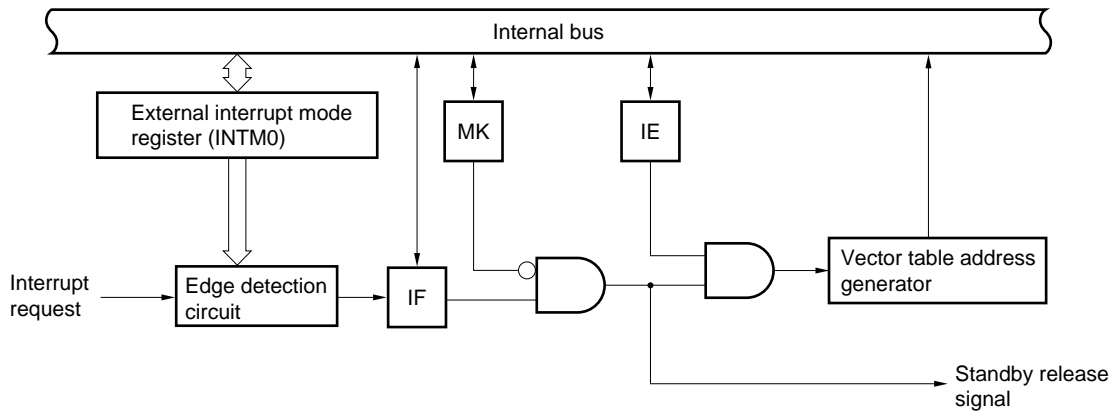

IF: Interrupt request flag  
 IE: Interrupt enable flag  
 MK: Interrupt mask flag

## 7. STANDBY FUNCTION

The following two standby functions are available for further reduction of system current consumption.

- HALT mode: In this mode, the CPU operation clock is stopped. The average current consumption can be reduced by intermittent operation by combining this mode with the normal operation mode.
- STOP mode: In this mode, oscillation of the system clock is stopped. All the operations performed on the system clock are suspended, resulting in extremely small power consumption.

**Figure 7-1. Standby Function**

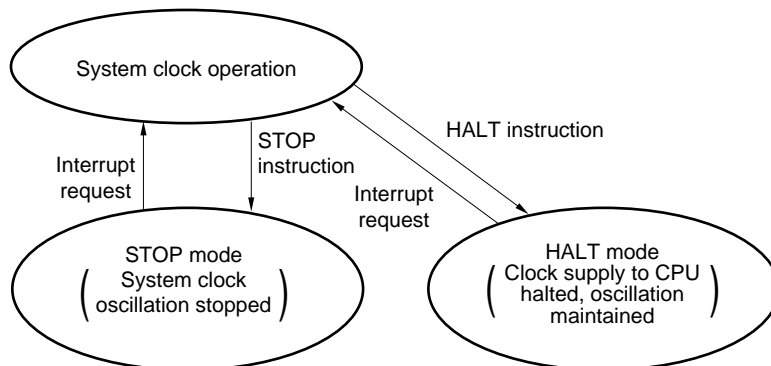

## 8. RESET FUNCTION

The following two reset methods are available.

- External reset by  $\overline{\text{RESET}}$  signal input
- Internal reset by watchdog timer runaway time detection

## 9. MASK OPTIONS

The  $\mu$ PD78912xA, 78913xA, 78912xA(A), and 78913xA(A) have the following mask options.

- Mask options for P50 to P53  
An on-chip pull-up resistor can be selected.  
<1> Specifies on-chip pull-up resistor in bit units.  
<2> Does not specify on-chip pull-up resistor.

**10. INSTRUCTION SET OVERVIEW**

The instruction set for the μPD78912xA, 78913xA, 78912xA(A), 78913xA(A) is listed later.

**10.1 Conventions**

**10.1.1 Operand identifiers and description methods**

Operands are described in the “Operand” column of each instruction in accordance with the description method of the instruction operand identifier (refer to the assembler specifications for detail). When there are two or more description methods, select one of them. Alphabetic letters in capitals and the symbols, #, !, \$, and [ ], are keywords and must be described as they are. Each symbol has the following meaning.

- #: Immediate data specification
- \$: Relative address specification
- !: Absolute address specification
- [ ]: Indirect address specification

In the case of immediate data, describe an appropriate numeric value or a label. When using a label, be sure to describe the #,!, \$, or [ ] symbols.

For operand register identifiers, r and rp, either function names (X, A, C, etc.) or absolute names (names in parentheses in the table below, R0, R1, R2, etc.) can be used for description.

**Table 10-1. Operand Identifiers and Description Methods**

Identifier	Description Method
r rp sfr	X (R0), A (R1), C (R2), B (R3), E (R4), D (R5), L (R6), H (R7), AX (RP0), BC (RP1), DE (RP2), HL (RP3) Special function register symbol
saddr saddrp	FE20H to FF1FH immediate data or label FE20H to FF1FH immediate data or label (even address only)
addr16 addr5	0000H to FFFFH immediate data or label (Only even addresses for 16-bit data transfer instructions) 0040H to 007FH immediate data or label (even address only)
word byte bit	16-bit immediate data or label 8-bit immediate data or label 3-bit immediate data or label

### 10.1.2 Descriptions of the operation field

A:	A register; 8-bit accumulator
X:	X register
B:	B register
C:	C register
D:	D register
E:	E register
H:	H register
L:	L register
AX:	AX register pair; 16-bit accumulator
BC:	BC register pair
DE:	DE register pair
HL:	HL register pair
PC:	Program counter
SP:	Stack pointer
PSW:	Program status word
CY:	Carry flag
AC:	Auxiliary carry flag
Z:	Zero flag
IE:	Interrupt request enable flag
NMIS:	Non-maskable interrupt servicing flag
( ):	Memory contents indicated by address or register contents in parentheses
X <sub>H</sub> , X <sub>L</sub> :	Higher 8 bits and lower 8 bits of 16-bit register
$\wedge$ :	Logical product (AND)
$\vee$ :	Logical sum (OR)
$\oplus$ :	Exclusive OR
$\overline{\quad}$ :	Inverted data
addr16:	16-bit immediate data or label
jdisp8:	Signed 8-bit data (displacement value)

### 10.1.3 Description of the flag operation field

(Blank):	Not affected
0:	Cleared to 0
1:	Set to 1
x:	Set/cleared according to the result
R:	Previously saved value is restored



10.2 Operations

Mnemonic	Operand	Byte	Clock	Operation	Flag		
					Z	AC	CY
MOV	r, #byte	3	6	$r \leftarrow \text{byte}$			
	saddr, #byte	3	6	$(\text{saddr}) \leftarrow \text{byte}$			
	sfr, #byte	3	6	$\text{sfr} \leftarrow \text{byte}$			
	A, r <small>Note 1</small>	2	4	$A \leftarrow r$			
	r, A <small>Note 1</small>	2	4	$r \leftarrow A$			
	A, saddr	2	4	$A \leftarrow (\text{saddr})$			
	saddr, A	2	4	$(\text{saddr}) \leftarrow A$			
	A, sfr	2	4	$A \leftarrow \text{sfr}$			
	sfr, A	2	4	$\text{sfr} \leftarrow A$			
	A, !addr16	3	8	$A \leftarrow (\text{addr16})$			
	!addr16, A	3	8	$(\text{addr16}) \leftarrow A$			
	PSW, #byte	3	6	$\text{PSW} \leftarrow \text{byte}$	x	x	x
	A, PSW	2	4	$A \leftarrow \text{PSW}$			
	PSW, A	2	4	$\text{PSW} \leftarrow A$	x	x	x
	A, [DE]	1	6	$A \leftarrow (\text{DE})$			
	[DE], A	1	6	$(\text{DE}) \leftarrow A$			
	A, [HL]	1	6	$A \leftarrow (\text{HL})$			
	[HL], A	1	6	$(\text{HL}) \leftarrow A$			
	A, [HL + byte]	2	6	$A \leftarrow (\text{HL} + \text{byte})$			
	[HL + byte], A	2	6	$(\text{HL} + \text{byte}) \leftarrow A$			
XCH	A, X	1	4	$A \leftrightarrow X$			
	A, r <small>Note 2</small>	2	6	$A \leftrightarrow r$			
	A, saddr	2	6	$A \leftrightarrow (\text{saddr})$			
	A, sfr	2	6	$A \leftrightarrow (\text{sfr})$			
	A, [DE]	1	8	$A \leftrightarrow (\text{DE})$			
	A, [HL]	1	8	$A \leftrightarrow (\text{HL})$			
	A, [HL + byte]	2	8	$A \leftrightarrow (\text{HL} + \text{byte})$			
MOVW	rp, #word	3	6	$\text{rp} \leftarrow \text{word}$			
	AX, saddrp	2	6	$\text{AX} \leftarrow (\text{saddrp})$			
	saddrp, AX	2	8	$(\text{saddrp}) \leftarrow \text{AX}$			
	AX, rp <small>Note 3</small>	1	4	$\text{AX} \leftarrow \text{rp}$			
	rp, AX <small>Note 3</small>	1	4	$\text{rp} \leftarrow \text{AX}$			
XCHW	AX, rp <small>Note 3</small>	1	8	$\text{AX} \leftrightarrow \text{rp}$			

- Notes**
1. Except  $r = A$
  2. Except  $r = A$  or  $X$
  3. Only when  $\text{rp} = \text{BC}, \text{DE}, \text{HL}$

**Remark** One instruction clock cycle is one cycle of the CPU clock ( $f_{\text{CPU}}$ ), selected by the processor clock control register (PCC).

Mnemonic	Operand	Byte	Clock	Operation	Flag		
					Z	AC	CY
ADD	A, #byte	2	4	$A, CY \leftarrow A + \text{byte}$	x	x	x
	saddr, #byte	3	6	$(\text{saddr}), CY \leftarrow (\text{saddr}) + \text{byte}$	x	x	x
	A, r	2	4	$A, CY \leftarrow A + r$	x	x	x
	A, saddr	2	4	$A, CY \leftarrow A + (\text{saddr})$	x	x	x
	A, !addr16	3	8	$A, CY \leftarrow A + (\text{addr16})$	x	x	x
	A, [HL]	1	6	$A, CY \leftarrow A + (\text{HL})$	x	x	x
	A, [HL + byte]	2	6	$A, CY \leftarrow A + (\text{HL} + \text{byte})$	x	x	x
ADDC	A, #byte	2	4	$A, CY \leftarrow A + \text{byte} + CY$	x	x	x
	saddr, #byte	3	6	$(\text{saddr}), CY \leftarrow (\text{saddr}) + \text{byte} + CY$	x	x	x
	A, r	2	4	$A, CY \leftarrow A + r + CY$	x	x	x
	A, saddr	2	4	$A, CY \leftarrow A + (\text{saddr}) + CY$	x	x	x
	A, !addr16	3	8	$A, CY \leftarrow A + (\text{addr16}) + CY$	x	x	x
	A, [HL]	1	6	$A, CY \leftarrow A + (\text{HL}) + CY$	x	x	x
	A, [HL + byte]	2	6	$A, CY \leftarrow A + (\text{HL} + \text{byte}) + CY$	x	x	x
SUB	A, #byte	2	4	$A, CY \leftarrow A - \text{byte}$	x	x	x
	saddr, #byte	3	6	$(\text{saddr}), CY \leftarrow (\text{saddr}) - \text{byte}$	x	x	x
	A, r	2	4	$A, CY \leftarrow A - r$	x	x	x
	A, saddr	2	4	$A, CY \leftarrow A - (\text{saddr})$	x	x	x
	A, !addr16	3	8	$A, CY \leftarrow A - (\text{addr16})$	x	x	x
	A, [HL]	1	6	$A, CY \leftarrow A - (\text{HL})$	x	x	x
	A, [HL + byte]	2	6	$A, CY \leftarrow A - (\text{HL} + \text{byte})$	x	x	x
SUBC	A, #byte	2	4	$A, CY \leftarrow A - \text{byte} - CY$	x	x	x
	saddr, #byte	3	6	$(\text{saddr}), CY \leftarrow (\text{saddr}) - \text{byte} - CY$	x	x	x
	A, r	2	4	$A, CY \leftarrow A - r - CY$	x	x	x
	A, saddr	2	4	$A, CY \leftarrow A - (\text{saddr}) - CY$	x	x	x
	A, !addr16	3	8	$A, CY \leftarrow A - (\text{addr16}) - CY$	x	x	x
	A, [HL]	1	6	$A, CY \leftarrow A - (\text{HL}) - CY$	x	x	x
	A, [HL + byte]	2	6	$A, CY \leftarrow A - (\text{HL} + \text{byte}) - CY$	x	x	x
AND	A, #byte	2	4	$A \leftarrow A \wedge \text{byte}$	x		
	saddr, #byte	3	6	$(\text{saddr}) \leftarrow (\text{saddr}) \wedge \text{byte}$	x		
	A, r	2	4	$A \leftarrow A \wedge r$	x		
	A, saddr	2	4	$A \leftarrow A \wedge (\text{saddr})$	x		
	A, !addr16	3	8	$A \leftarrow A \wedge (\text{addr16})$	x		
	A, [HL]	1	6	$A \leftarrow A \wedge (\text{HL})$	x		
	A, [HL + byte]	2	6	$A \leftarrow A \wedge (\text{HL} + \text{byte})$	x		

**Remark** One instruction clock cycle is one cycle of the CPU clock ( $f_{CPU}$ ), selected by the processor clock control register (PCC).

Mnemonic	Operand	Byte	Clock	Operation	Flag		
					Z	AC	CY
OR	A, #byte	2	4	$A \leftarrow A \vee \text{byte}$	x		
	saddr, #byte	3	6	$(\text{saddr}) \leftarrow (\text{saddr}) \vee \text{byte}$	x		
	A, r	2	4	$A \leftarrow A \vee r$	x		
	A, saddr	2	4	$A \leftarrow A \vee (\text{saddr})$	x		
	A, !addr16	3	8	$A \leftarrow A \vee (\text{addr16})$	x		
	A, [HL]	1	6	$A \leftarrow A \vee (\text{HL})$	x		
	A, [HL + byte]	2	6	$A \leftarrow A \vee (\text{HL} + \text{byte})$	x		
XOR	A, #byte	2	4	$A \leftarrow A \nabla \text{byte}$	x		
	saddr, #byte	3	6	$(\text{saddr}) \leftarrow (\text{saddr}) \nabla \text{byte}$	x		
	A, r	2	4	$A \leftarrow A \nabla r$	x		
	A, saddr	2	4	$A \leftarrow A \nabla (\text{saddr})$	x		
	A, !addr16	3	8	$A \leftarrow A \nabla (\text{addr16})$	x		
	A, [HL]	1	6	$A \leftarrow A \nabla (\text{HL})$	x		
	A, [HL + byte]	2	6	$A \leftarrow A \nabla (\text{HL} + \text{byte})$	x		
CMP	A, #byte	2	4	$A - \text{byte}$	x	x	x
	saddr, #byte	3	6	$(\text{saddr}) - \text{byte}$	x	x	x
	A, r	2	4	$A - r$	x	x	x
	A, saddr	2	4	$A - (\text{saddr})$	x	x	x
	A, !addr16	3	8	$A - (\text{addr16})$	x	x	x
	A, [HL]	1	6	$A - (\text{HL})$	x	x	x
	A, [HL + byte]	2	6	$A - (\text{HL} + \text{byte})$	x	x	x
ADDW	AX, #word	3	6	$\text{AX}, \text{CY} \leftarrow \text{AX} + \text{word}$	x	x	x
SUBW	AX, #word	3	6	$\text{AX}, \text{CY} \leftarrow \text{AX} - \text{word}$	x	x	x
CMPW	AX, #word	3	6	$\text{AX} - \text{word}$	x	x	x
INC	r	2	4	$r \leftarrow r + 1$	x	x	
	saddr	2	4	$(\text{saddr}) \leftarrow (\text{saddr}) + 1$	x	x	
DEC	r	2	4	$r \leftarrow r - 1$	x	x	
	saddr	2	4	$(\text{saddr}) \leftarrow (\text{saddr}) - 1$	x	x	
INCW	rp	1	4	$\text{rp} \leftarrow \text{rp} + 1$			
DECW	rp	1	4	$\text{rp} \leftarrow \text{rp} - 1$			
ROR	A, 1	1	2	$(\text{CY}, A_7 \leftarrow A_0, A_{m-1} \leftarrow A_m) \times 1$			x
ROL	A, 1	1	2	$(\text{CY}, A_0 \leftarrow A_7, A_{m+1} \leftarrow A_m) \times 1$			x
RORC	A, 1	1	2	$(\text{CY} \leftarrow A_0, A_7 \leftarrow \text{CY}, A_{m-1} \leftarrow A_m) \times 1$			x
ROLC	A, 1	1	2	$(\text{CY} \leftarrow A_7, A_0 \leftarrow \text{CY}, A_{m+1} \leftarrow A_m) \times 1$			x

**Remark** One instruction clock cycle is one cycle of the CPU clock (f<sub>cpu</sub>), selected by the processor clock control register (PCC).

Mnemonic	Operand	Byte	Clock	Operation	Flag		
					Z	AC	CY
SET1	saddr. bit	3	6	(saddr. bit) ← 1			
	sfr. bit	3	6	sfr. bit ← 1			
	A. bit	2	4	A. bit ← 1			
	PSW. bit	3	6	PSW. bit ← 1	x	x	x
	[HL]. bit	2	10	(HL). bit ← 1			
CLR1	saddr. bit	3	6	(saddr. bit) ← 0			
	sfr. bit	3	6	sfr. bit ← 0			
	A. bit	2	4	A. bit ← 0			
	PSW. bit	3	6	PSW. bit ← 0	x	x	x
	[HL]. bit	2	10	(HL). bit ← 0			
SET1	CY	1	2	CY ← 1			1
CLR1	CY	1	2	CY ← 0			0
NOT1	CY	1	2	CY ← $\overline{\text{CY}}$			x
CALL	laddr16	3	6	(SP - 1) ← (PC + 3) <sub>H</sub> , (SP - 2) ← (PC + 3) <sub>L</sub> , PC ← addr16, SP ← SP - 2			
CALLT	[addr5]	1	8	(SP - 1) ← (PC + 1) <sub>H</sub> , (SP - 2) ← (PC + 1) <sub>L</sub> , PC <sub>H</sub> ← (00000000, addr5 + 1), PC <sub>L</sub> ← (00000000, addr5), SP ← SP - 2			
RET		1	6	PC <sub>H</sub> ← (SP + 1), PC <sub>L</sub> ← (SP), SP ← SP + 2			
RETI		1	8	PC <sub>H</sub> ← (SP + 1), PC <sub>L</sub> ← (SP), PSW ← (SP + 2), SP ← SP + 3, NMIS ← 0	R	R	R
PUSH	PSW	1	2	(SP - 1) ← PSW, SP ← SP - 1			
	rp	1	4	(SP - 1) ← rp <sub>H</sub> , (SP - 2) ← rp <sub>L</sub> , SP ← SP - 2			
POP	PSW	1	4	PSW ← (SP), SP ← SP + 1	R	R	R
	rp	1	6	rp <sub>H</sub> ← (SP + 1), rp <sub>L</sub> ← (SP), SP ← SP + 2			
MOVW	SP, AX	2	8	SP ← AX			
	AX, SP	2	6	AX ← SP			
BR	laddr16	3	6	PC ← addr16			
	\$addr16	2	6	PC ← PC + 2 + jdisp8			
	AX	1	6	PC <sub>H</sub> ← A, PC <sub>L</sub> ← X			

**Remark** One instruction clock cycle is one cycle of the CPU clock (f<sub>CPU</sub>), selected by the processor clock control register (PCC).

Mnemonic	Operand	Byte	Clock	Operation	Flag		
					Z	AC	CY
BC	\$addr16	2	6	$PC \leftarrow PC + 2 + jdisp8$ if $CY = 1$			
BNC	\$addr16	2	6	$PC \leftarrow PC + 2 + jdisp8$ if $CY = 0$			
BZ	\$addr16	2	6	$PC \leftarrow PC + 2 + jdisp8$ if $Z = 1$			
BNZ	\$addr16	2	6	$PC \leftarrow PC + 2 + jdisp8$ if $Z = 0$			
BT	saddr. bit, \$addr16	4	10	$PC \leftarrow PC + 4 + jdisp8$ if (saddr. bit) = 1			
	sfr. bit, \$addr16	4	10	$PC \leftarrow PC + 4 + jdisp8$ if sfr. bit = 1			
	A. bit, \$addr16	3	8	$PC \leftarrow PC + 3 + jdisp8$ if A. bit = 1			
	PSW. bit, \$addr16	4	10	$PC \leftarrow PC + 4 + jdisp8$ if PSW. bit = 1			
BF	saddr. bit, \$addr16	4	10	$PC \leftarrow PC + 4 + jdisp8$ if (saddr. bit) = 0			
	sfr. bit, \$addr16	4	10	$PC \leftarrow PC + 4 + jdisp8$ if sfr. bit = 0			
	A. bit, \$addr16	3	8	$PC \leftarrow PC + 3 + jdisp8$ if A. bit = 0			
	PSW. bit, \$addr16	4	10	$PC \leftarrow PC + 4 + jdisp8$ if PSW. bit = 0			
DBNZ	B, \$addr16	2	6	$B \leftarrow B - 1$ , then $PC \leftarrow PC + 2 + jdisp8$ if $B \neq 0$			
	C, \$addr16	2	6	$C \leftarrow C - 1$ , then $PC \leftarrow PC + 2 + jdisp8$ if $C \neq 0$			
	saddr, \$addr16	3	8	(saddr) $\leftarrow$ (saddr) - 1, then $PC \leftarrow PC + 3 + jdisp8$ if (saddr) $\neq$ 0			
NOP		1	2	No Operation			
EI		3	6	$IE \leftarrow 1$ (Enable Interrupt)			
DI		3	6	$IE \leftarrow 0$ (Disable Interrupt)			
HALT		1	2	Set HALT Mode			
STOP		1	2	Set STOP Mode			

**Remark** One instruction clock cycle is one cycle of the CPU clock ( $f_{CPU}$ ), selected by the processor clock control register (PCC).

### 11. ELECTRICAL SPECIFICATIONS

#### Absolute Maximum Ratings (T<sub>A</sub> = 25°C)

Parameter	Symbol	Conditions		Ratings	Unit
Supply voltage	V <sub>DD</sub> , AV <sub>DD</sub>	V <sub>DD</sub> = AV <sub>DD</sub>		-0.3 to +6.5	V
Input voltage	V <sub>I1</sub>	Pins other than P50 to P53		-0.3 to V <sub>DD</sub> + 0.3	V
	V <sub>I2</sub>	P50 to P53	With N-ch open drain	-0.3 to +13	V
			With an on-chip pull-up resistor	-0.3 to V <sub>DD</sub> + 0.3	V
Output voltage	V <sub>O</sub>			-0.3 to V <sub>DD</sub> + 0.3	V
Output current, high	I <sub>OH</sub>	Per pin	μPD78912xA, 78913xA	-10	mA
		Total for all pins		-30	mA
		Per pin	μPD78912xA(A), 78913xA(A)	-7	mA
		Total for all pins		-22	mA
Output current, low	I <sub>OL</sub>	Per pin	μPD78912xA, 78913xA	30	mA
		Total for all pins		160	mA
		Per pin	μPD78912xA(A), 78913xA(A)	10	mA
		Total for all pins		120	mA
Operating ambient temperature	T <sub>A</sub>			-40 to +85	°C
Storage temperature	T <sub>stg</sub>			-65 to +150	°C

**Caution** Product quality may suffer if the absolute maximum rating is exceeded even momentarily for any parameter. That is, the absolute maximum ratings are rated values at which the product is on the verge of suffering physical damage, and therefore the product must be used under conditions that ensure that the absolute maximum ratings are not exceeded.

**Remark** Unless specified otherwise, the characteristics of alternate-function pins are the same as those of port pins.

**System Clock Oscillator Characteristics (T<sub>A</sub> = -40 to +85°C, V<sub>DD</sub> = 1.8 to 5.5 V)**

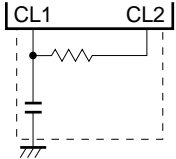
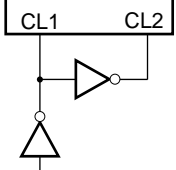
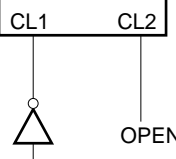
Resonator	Recommended Circuit	Parameter	Conditions	MIN.	TYP.	MAX.	Unit
RC resonator		Oscillation frequency (f <sub>cc</sub> ) <sup>Note</sup>		2.0		4.0	MHz
External clock		CL1 input frequency (f <sub>cc</sub> ) <sup>Note</sup>		1.0		5.0	MHz
		CL1 input high-/low-level width (t <sub>xH</sub> , t <sub>xL</sub> )		85		500	ns
		CL1 input frequency (f <sub>cc</sub> ) <sup>Note</sup>	V <sub>DD</sub> = 2.7 to 5.5 V	1.0		5.0	MHz
		CL1 input high-/low-level width (t <sub>xH</sub> , t <sub>xL</sub> )		85		500	ns

**Note** Indicates only oscillator characteristics. Refer to **AC characteristics** for instruction execution time.

**Caution** When using the system clock oscillator, wire as follows in the area enclosed by the broken lines in the above figures to avoid an adverse effect from wiring capacitance.

- Keep the wiring length as short as possible.
- Do not cross the wiring with the other signal lines.
- Do not route the wiring near a signal line through which a high fluctuating current flows.
- Always make the ground point of the oscillator capacitor the same potential as V<sub>SS</sub>.
- Do not ground the capacitor to a ground pattern through which a high current flows.
- Do not fetch signals from the oscillator.

**RC Oscillator Frequency Characteristics (T<sub>A</sub> = -40 to +85°C)**

Parameter	Symbol	Conditions	MIN.	TYP.	MAX.	Unit	
Oscillator frequency	f <sub>cc1</sub>	R = 11.0 kΩ, C = 22 pF	V <sub>DD</sub> = 2.7 to 5.5 V	1.5	2.0	2.5	MHz
	f <sub>cc2</sub>	Target: 2 MHz	V <sub>DD</sub> = 1.8 to 3.6 V	0.5	2.0	2.5	MHz
	f <sub>cc3</sub>		V <sub>DD</sub> = 1.8 to 5.5 V	0.5	2.0	2.5	MHz
	f <sub>cc4</sub>	R = 6.8 kΩ, C = 22 pF	V <sub>DD</sub> = 2.7 to 5.5 V	2.5	3.0	3.5	MHz
	f <sub>cc5</sub>	Target: 3 MHz	V <sub>DD</sub> = 1.8 to 3.6 V	0.75	3.0	3.5	MHz
	f <sub>cc6</sub>		V <sub>DD</sub> = 1.8 to 5.5 V	0.75	3.0	3.5	MHz
	f <sub>cc7</sub>	R = 4.7 kΩ, C = 22 pF	V <sub>DD</sub> = 2.7 to 5.5 V	3.5	4.0	4.7	MHz
	f <sub>cc8</sub>	Target: 4 MHz	V <sub>DD</sub> = 1.8 to 3.6 V	1.0	4.0	4.7	MHz
	f <sub>cc9</sub>		V <sub>DD</sub> = 1.8 to 5.5 V	1.0	4.0	4.7	MHz

**Remark** So that the TYP. spec. is satisfied between 2.0 to 4.0 MHz, set one of the above nine patterns for R and C.

DC Characteristics (T<sub>A</sub> = -40 to +85°C, V<sub>DD</sub> = 1.8 to 5.5 V) (1/2)

Parameter	Symbol	Conditions		MIN.	TYP.	MAX.	Unit	
Output current, high	I <sub>OH</sub>	Per pin	μPD78912xA, 78913xA			-1	mA	
		Total for all pins				-15	mA	
		Per pin	μPD78912xA(A), 78913xA(A)			-1	mA	
		Total for all pins				-11	mA	
Output current, low	I <sub>OL</sub>	Per pin	μPD78912xA, 78913xA			10	mA	
		Total for all pins				80	mA	
		Per pin	μPD78912xA(A), 78913xA(A)			3	mA	
		Total for all pins				60	mA	
Input voltage, high	V <sub>IH1</sub>	Pins other than described below		V <sub>DD</sub> = 2.7 to 5.5 V	0.7 V <sub>DD</sub>	V <sub>DD</sub>	V	
					0.9 V <sub>DD</sub>	V <sub>DD</sub>	V	
	V <sub>IH2</sub>	P50 to P53	With N-ch open drain	V <sub>DD</sub> = 2.7 to 5.5 V	0.7 V <sub>DD</sub>	12	V	
					0.9 V <sub>DD</sub>	12	V	
				With on-chip pull-up resistor	V <sub>DD</sub> = 2.7 to 5.5 V	0.7 V <sub>DD</sub>	V <sub>DD</sub>	V
						0.9 V <sub>DD</sub>	V <sub>DD</sub>	V
	V <sub>IH3</sub>	RESET, P20 to P25		V <sub>DD</sub> = 2.7 to 5.5 V	0.8 V <sub>DD</sub>	V <sub>DD</sub>	V	
					0.9 V <sub>DD</sub>	V <sub>DD</sub>	V	
V <sub>IH4</sub>	CL1, CL2		V <sub>DD</sub> = 4.5 to 5.5 V	V <sub>DD</sub> -0.5	V <sub>DD</sub>	V		
				V <sub>DD</sub> -0.1	V <sub>DD</sub>	V		
Input voltage, low	V <sub>IL1</sub>	Pins other than described below		V <sub>DD</sub> = 2.7 to 5.5 V	0	0.3 V <sub>DD</sub>	V	
					0	0.1 V <sub>DD</sub>	V	
	V <sub>IL2</sub>	P50 to P53		V <sub>DD</sub> = 2.7 to 5.5 V	0	0.3 V <sub>DD</sub>	V	
					0	0.1 V <sub>DD</sub>	V	
	V <sub>IL3</sub>	RESET, P20 to P25		V <sub>DD</sub> = 2.7 to 5.5 V	0	0.2 V <sub>DD</sub>	V	
					0	0.1 V <sub>DD</sub>	V	
	V <sub>IL4</sub>	CL1, CL2		V <sub>DD</sub> = 4.5 to 5.5 V	0	0.4	V	
					0	0.1	V	
Output voltage, high	V <sub>OH1</sub>	V <sub>DD</sub> = 4.5 to 5.5 V, I <sub>OH</sub> = -1 mA		V <sub>DD</sub> -1.0			V	
	V <sub>OH2</sub>	V <sub>DD</sub> = 1.8 to 5.5 V, I <sub>OH</sub> = -100 μA		V <sub>DD</sub> -0.5			V	
Output voltage, low	V <sub>OL1</sub>	Pins other than P50 to P53	V <sub>DD</sub> = 4.5 to 5.5 V, I <sub>OL</sub> = 10 mA (μPD78912xA, 78913xA)			1.0	V	
			V <sub>DD</sub> = 4.5 to 5.5 V, I <sub>OL</sub> = 3 mA (μPD78912xA(A), 78913xA(A))			1.0	V	
			V <sub>DD</sub> = 1.8 to 5.5 V, I <sub>OL</sub> = 400 μA			0.5	V	
	V <sub>OL2</sub>	P50 to P53	V <sub>DD</sub> = 4.5 to 5.5 V, I <sub>OL</sub> = 10 mA (μPD78912xA, 78913xA)			1.0	V	
			V <sub>DD</sub> = 4.5 to 5.5 V, I <sub>OL</sub> = 3 mA (μPD78912xA(A), 78913xA(A))			1.0	V	
			V <sub>DD</sub> = 1.8 to 5.5 V, I <sub>OL</sub> = 1.6 mA			0.4	V	

**Remark** Unless specified otherwise, the characteristics of alternate-function pins are the same as those of port pins.



DC Characteristics (T<sub>A</sub> = -40 to +85°C, V<sub>DD</sub> = 1.8 to 5.5 V) (2/2)

Parameter	Symbol	Conditions		MIN.	TYP.	MAX.	Unit
Input leakage current, high	I <sub>LIH1</sub>	Pins other than CL1, CL2, or P50 to P53	V <sub>IN</sub> = V <sub>DD</sub>			3	μA
	I <sub>LIH2</sub>	CL1, CL2				20	μA
	I <sub>LIH3</sub>	P50 to P53 (N-ch open drain)	V <sub>IN</sub> = 12 V			20	μA
Input leakage current, low	I <sub>LIL1</sub>	Pins other than CL1, CL2, or P50 to P53	V <sub>IN</sub> = 0 V			-3	μA
	I <sub>LIL2</sub>	CL1, CL2				-20	μA
	I <sub>LIL3</sub>	P50 to P53 (N-ch open drain)				-3 <sup>Note 1</sup>	μA
Output leakage current, high	I <sub>LOH</sub>	V <sub>OUT</sub> = V <sub>DD</sub>				3	μA
Output leakage current, low	I <sub>LOL</sub>	V <sub>OUT</sub> = 0 V				-3	μA
Software pull-up resistor	R <sub>1</sub>	V <sub>IN</sub> = 0 V, for pins other than P50 to P53		50	100	200	kΩ
Mask option pull-up resistor	R <sub>2</sub>	V <sub>IN</sub> = 0 V, P50 to P53		10	30	60	kΩ
Power supply current	I <sub>DD1</sub> <sup>Note 2</sup>	4.0-MHz RC oscillation operating mode (R = 4.7 kΩ, C = 22pF)	V <sub>DD</sub> = 5.0 V±10% <sup>Note 4</sup>		1.8	3.2	mA
			V <sub>DD</sub> = 3.0 V±10% <sup>Note 5</sup>		0.45	0.9	mA
			V <sub>DD</sub> = 2.0 V±10% <sup>Note 5</sup>		0.25	0.45	mA
	I <sub>DD2</sub> <sup>Note 2</sup>	4.0-MHz RC oscillation HALT mode (R = 4.7 kΩ, C = 22pF)	V <sub>DD</sub> = 5.0 V±10% <sup>Note 4</sup>		0.8	1.6	mA
			V <sub>DD</sub> = 3.0 V±10% <sup>Note 5</sup>		0.3	0.6	mA
			V <sub>DD</sub> = 2.0 V±10% <sup>Note 5</sup>		0.15	0.3	mA
	I <sub>DD3</sub> <sup>Note 2</sup>	STOP mode	V <sub>DD</sub> = 5.0 V±10%		0.1	10	μA
			V <sub>DD</sub> = 3.0 V±10%		0.05	5.0	μA
			V <sub>DD</sub> = 2.0 V±10%		0.05	5.0	μA
	I <sub>DD4</sub> <sup>Note 3</sup>	4.0-MHz RC oscillation A/D operating mode (R = 4.7 kΩ, C = 22pF)	V <sub>DD</sub> = 5.0 V±10% <sup>Note 4</sup>		3.0	5.5	mA
V <sub>DD</sub> = 3.0 V±10% <sup>Note 5</sup>				1.65	3.2	mA	
V <sub>DD</sub> = 2.0 V±10% <sup>Note 5</sup>				1.25	2.7	mA	

- Notes**
1. When pull-up resistors are not connected to P50 to P53 (specified by the mask option) and when port 5 is in input mode, a low-level input leakage current of -60 μA (MAX.) flows only for 1 cycle time after a read instruction has been executed to port 5.
  2. The current flowing to the ports (including the current flowing through an on-chip pull-up resistor) and AV<sub>DD</sub> current are not included.
  3. The current flowing to the ports (including the current flowing through an on-chip pull-up resistor) is not included.
  4. High-speed mode operation (when processor clock control register (PCC) is set to 00H.)
  5. Low-speed mode operation (when PCC is set to 02H).

**Remark** Unless specified otherwise, the characteristics of alternate-function pins are the same as those of port pins.

AC Characteristics

(1) Basic operation (TA = -40 to +85°C, VDD = 1.8 to 5.5 V)

Parameter	Symbol	Conditions	MIN.	TYP.	MAX.	Unit
Cycle time (minimum instruction execution time)	T <sub>CY</sub>	V <sub>DD</sub> = 2.7 to 5.5 V	0.4		8	μs
			1.6		8	μs
T180 input high-/low- level width	t <sub>TIH</sub> , t <sub>TIL</sub>	V <sub>DD</sub> = 2.7 to 5.5 V	0.1			μs
			1.8			μs
T180 input frequency	f <sub>TI</sub>	V <sub>DD</sub> = 2.7 to 5.5 V	0		4	MHz
			0		275	kHz
Interrupt input high- /low-level width	t <sub>INTH</sub> , t <sub>INTL</sub>	INTP0 to INTP2	10			μs
RESET low-level width	t <sub>RSL</sub>		10			μs
CPT20 input high- /low-level width	t <sub>CPH</sub> , t <sub>CPL</sub>		10			μs

T<sub>CY</sub> vs V<sub>DD</sub>

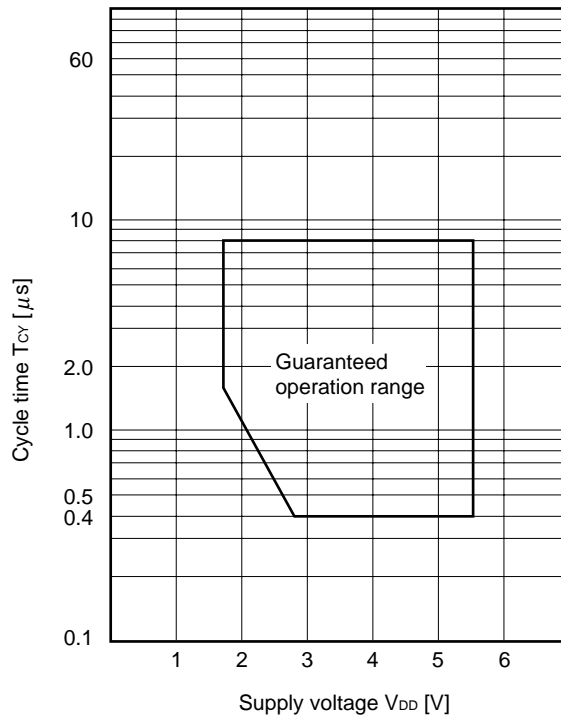

(2) Serial interface (T<sub>A</sub> = -40 to +85°C, V<sub>DD</sub> = 1.8 to 5.5 V)

(i) 3-wire serial I/O mode (SCK20...Internal clock output)

Parameter	Symbol	Conditions	MIN.	TYP.	MAX.	Unit
SCK20 cycle time	t <sub>KCY1</sub>	V <sub>DD</sub> = 2.7 to 5.5 V	800			ns
			3200			ns
SCK20 high-/low-level width	t <sub>KH1</sub> , t <sub>KL1</sub>	V <sub>DD</sub> = 2.7 to 5.5 V	t <sub>KCY1</sub> /2 - 50			ns
			t <sub>KCY1</sub> /2 - 150			ns
SI20 setup time (to SCK20↑)	t <sub>SIK1</sub>	V <sub>DD</sub> = 2.7 to 5.5 V	150			ns
			500			ns
SI20 hold time (from SCK20↑)	t <sub>KS1</sub>	V <sub>DD</sub> = 2.7 to 5.5 V	400			ns
			600			ns
SO20 output delay time from SCK20↓	t <sub>KSO1</sub>	R = 1 kΩ, C = 100 pF <sup>Note</sup>	V <sub>DD</sub> = 2.7 to 5.5 V		250	ns
				0	1000	ns

**Note** R and C are the load resistance and load capacitance of the SO output line.

(ii) 3-wire serial I/O mode (SCK20...External clock input)

Parameter	Symbol	Conditions	MIN.	TYP.	MAX.	Unit
SCK20 cycle time	t <sub>KCY2</sub>	V <sub>DD</sub> = 2.7 to 5.5 V	800			ns
			3200			ns
SCK20 high-/low-level width	t <sub>KH2</sub> , t <sub>KL2</sub>	V <sub>DD</sub> = 2.7 to 5.5 V	400			ns
			1600			ns
SI20 setup time (to SCK20↑)	t <sub>SIK2</sub>	V <sub>DD</sub> = 2.7 to 5.5 V	100			ns
			150			ns
SI20 hold time (from SCK20↑)	t <sub>KS2</sub>	V <sub>DD</sub> = 2.7 to 5.5 V	400			ns
			600			ns
SO20 output delay time from SCK20↓	t <sub>KSO2</sub>	R = 1 kΩ, C = 100 pF <sup>Note</sup>	V <sub>DD</sub> = 2.7 to 5.5 V		300	ns
				0	1000	ns
SO20 setup time (for SS20↓ when SS20 is used)	t <sub>KAS2</sub>	V <sub>DD</sub> = 2.7 to 5.5 V			120	ns
					400	ns
SO20 disable time (for SS20↑ when SS20 is used)	t <sub>KDS2</sub>	V <sub>DD</sub> = 2.7 to 5.5 V			240	ns
					800	ns

**Note** R and C are the load resistance and load capacitance of the SO output line.

(iii) UART mode (Dedicated baud rate generator output)

Parameter	Symbol	Conditions	MIN.	TYP.	MAX.	Unit
Transfer rate		V <sub>DD</sub> = 2.7 to 5.5 V			78125	bps
					19531	bps

**(iv) UART mode (external clock input)**

Parameter	Symbol	Conditions	MIN.	TYP.	MAX.	Unit
ASCK20 cycle time	t <sub>KCY3</sub>	V <sub>DD</sub> = 2.7 to 5.5 V	800			ns
			3200			ns
ASCK20 high-/low-level width	t <sub>KH3</sub> , t <sub>KL3</sub>	V <sub>DD</sub> = 2.7 to 5.5 V	400			ns
			1600			ns
Transfer rate		V <sub>DD</sub> = 2.7 to 5.5 V			39063	bps
					9766	bps
ASCK20 rise/fall time	t <sub>R</sub> , t <sub>F</sub>				1	μs

AC Timing Test Points (excluding CL1 input)

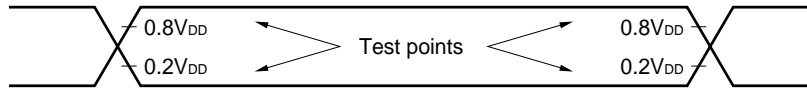

Clock Timing

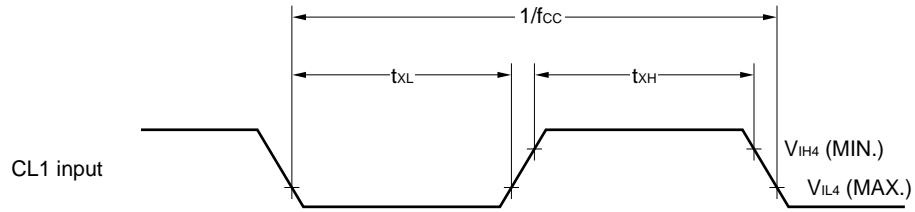

TI Timing

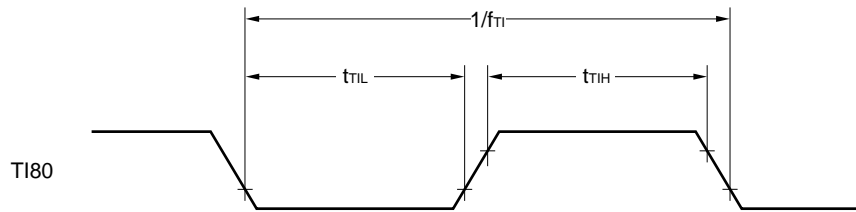

Interrupt Input Timing

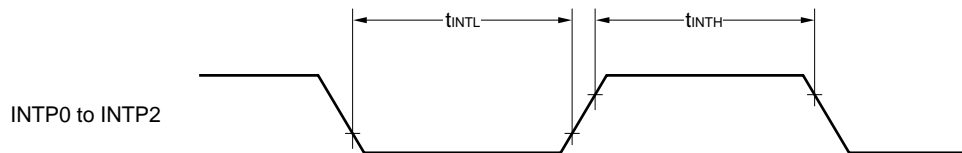

RESET Input Timing

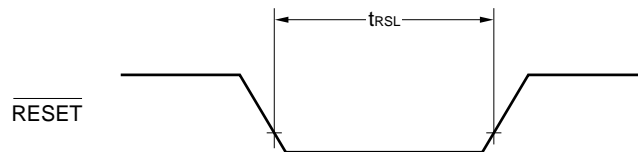

Serial Transfer Timing

3-wire serial I/O mode:

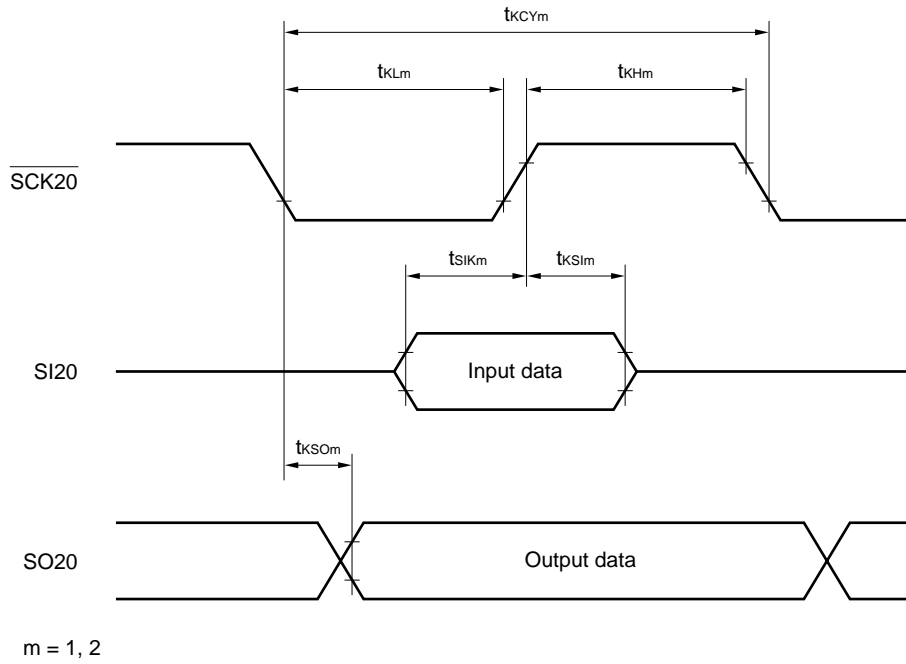

3-wire serial I/O mode (when  $\overline{\text{SS20}}$  is used):

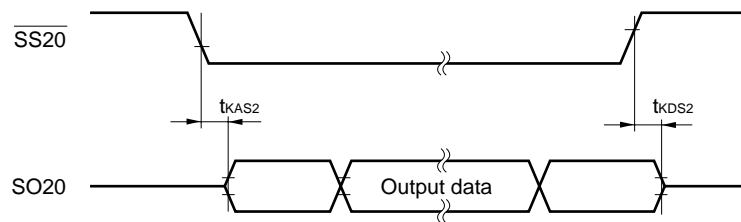

UART mode (external clock input):

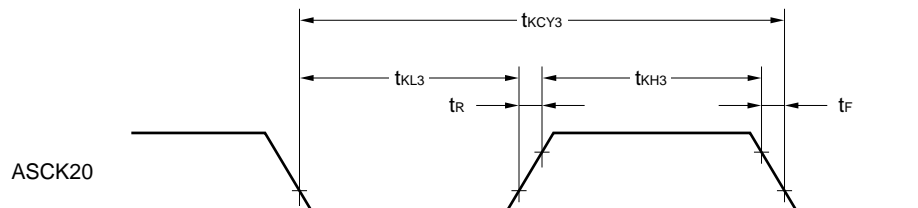

**8-Bit A/D Converter Characteristics (μPD78912xA, 78912xA(A))**

(T<sub>A</sub> = -40 to +85°C, AV<sub>DD</sub> = V<sub>DD</sub> = 1.8 to 5.5 V, AV<sub>SS</sub> = V<sub>SS</sub> = 0 V)

Parameter	Symbol	Conditions	MIN.	TYP.	MAX.	Unit
Resolution			8	8	8	bit
Overall error <sup>Note1,2</sup>		V <sub>DD</sub> = 2.7 to 5.5 V		±0.4	±0.6	%FSR
				±0.8	±1.2	%FSR
Conversion time	t <sub>CONV</sub>	V <sub>DD</sub> = 2.7 to 5.5 V	14		100	μs
			28		100	μs
Analog input voltage	V <sub>IAN</sub>		0		AV <sub>DD</sub>	V

- Notes**
1. Excludes quantization error (±0.2%FSR).
  2. It is indicated as a ratio to the full-scale value (%FSR).

**10-Bit A/D Converter Characteristics (μPD78913xA, 78913xA(A))**

(T<sub>A</sub> = -40 to +85°C, AV<sub>DD</sub> = V<sub>DD</sub> = 1.8 to 5.5 V, AV<sub>SS</sub> = V<sub>SS</sub> = 0 V)

Parameter	Symbol	Conditions	MIN.	TYP.	MAX.	Unit
Resolution			10	10	10	bit
Overall error <sup>Note1,2</sup>		4.5 V ≤ V <sub>DD</sub> ≤ 5.5 V		±0.2	±0.4	%FSR
		2.7 V ≤ V <sub>DD</sub> < 4.5 V		±0.4	±0.6	%FSR
		1.8 V ≤ V <sub>DD</sub> < 2.7 V		±0.8	±1.2	%FSR
Conversion time	t <sub>CONV</sub>	2.7 V ≤ V <sub>DD</sub> ≤ 5.5 V	14		100	μs
		1.8 V ≤ V <sub>DD</sub> < 2.7 V	28		100	μs
Zero-scale error <sup>Note1,2</sup>		4.5 V ≤ V <sub>DD</sub> ≤ 5.5 V			±0.4	%FSR
		2.7 V ≤ V <sub>DD</sub> < 4.5 V			±0.6	%FSR
		1.8 V ≤ V <sub>DD</sub> < 2.7 V			±1.2	%FSR
Full-scale error <sup>Note1,2</sup>		4.5 V ≤ V <sub>DD</sub> ≤ 5.5 V			±0.4	%FSR
		2.7 V ≤ V <sub>DD</sub> < 4.5 V			±0.6	%FSR
		1.8 V ≤ V <sub>DD</sub> < 2.7 V			±1.2	%FSR
Integral linearity error <sup>Note1</sup>	ILE	4.5 V ≤ V <sub>DD</sub> ≤ 5.5 V			±2.5	LSB
		2.7 V ≤ V <sub>DD</sub> < 4.5 V			±4.5	LSB
		1.8 V ≤ V <sub>DD</sub> < 2.7 V			±8.5	LSB
Differential linearity error <sup>Note1</sup>	DLE	4.5 V ≤ V <sub>DD</sub> ≤ 5.5 V			±1.5	LSB
		2.7 V ≤ V <sub>DD</sub> < 4.5 V			±2.0	LSB
		1.8 V ≤ V <sub>DD</sub> < 2.7 V			±3.5	LSB
Analog input voltage	V <sub>IAN</sub>		0		AV <sub>DD</sub>	V

- Notes**
1. Excludes quantization error (±0.05%FSR).
  2. It is indicated as a ratio to the full-scale value (%FSR).

**Data Memory STOP Mode Low Supply Voltage Data Retention Characteristics (T<sub>A</sub> = -40 to +85°C)**

Parameter	Symbol	Conditions	MIN.	TYP.	MAX.	Unit
Data retention supply voltage	V <sub>DDDR</sub>		1.8		5.5	V
Release signal set time	t <sub>SREL</sub>		0			μs
Oscillation stabilization wait time <sup>Note</sup>	t <sub>WAIT</sub>	Release by $\overline{\text{RESET}}$		2 <sup>7</sup> /f <sub>cc</sub>		ms
		Release by interrupt request		2 <sup>7</sup> /f <sub>cc</sub>		ms

**Note** The oscillation stabilization wait time is the period during which the CPU operation is stopped to avoid unstable operation at the beginning of oscillation.

**Remark** f<sub>cc</sub>: System clock oscillation frequency

**Data Retention Timing (STOP mode release by  $\overline{\text{RESET}}$ )**

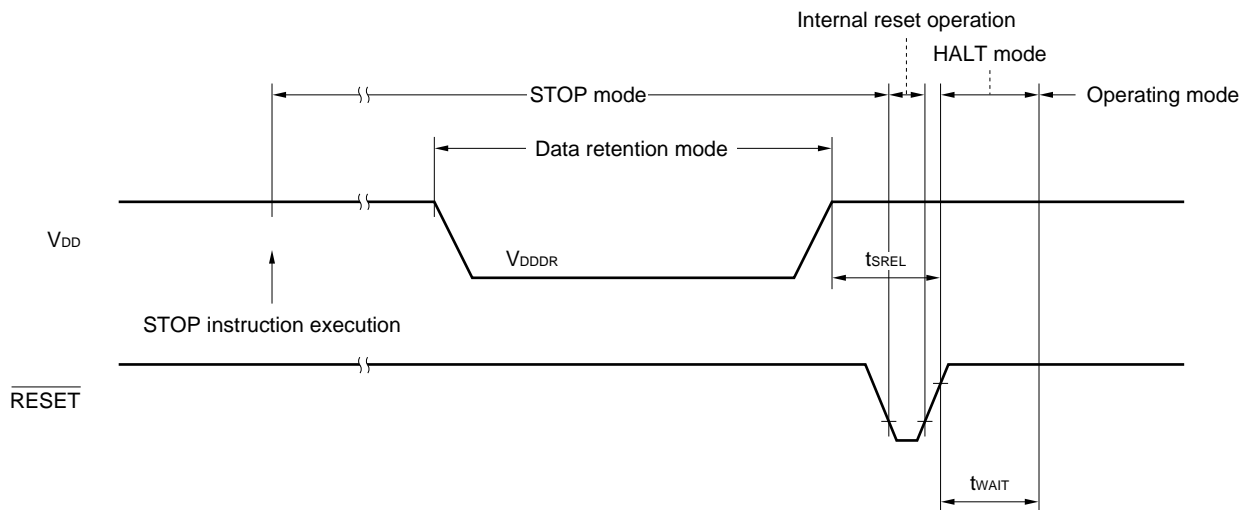

**Data Retention Timing (Standby release signal: STOP mode release by interrupt signal)**

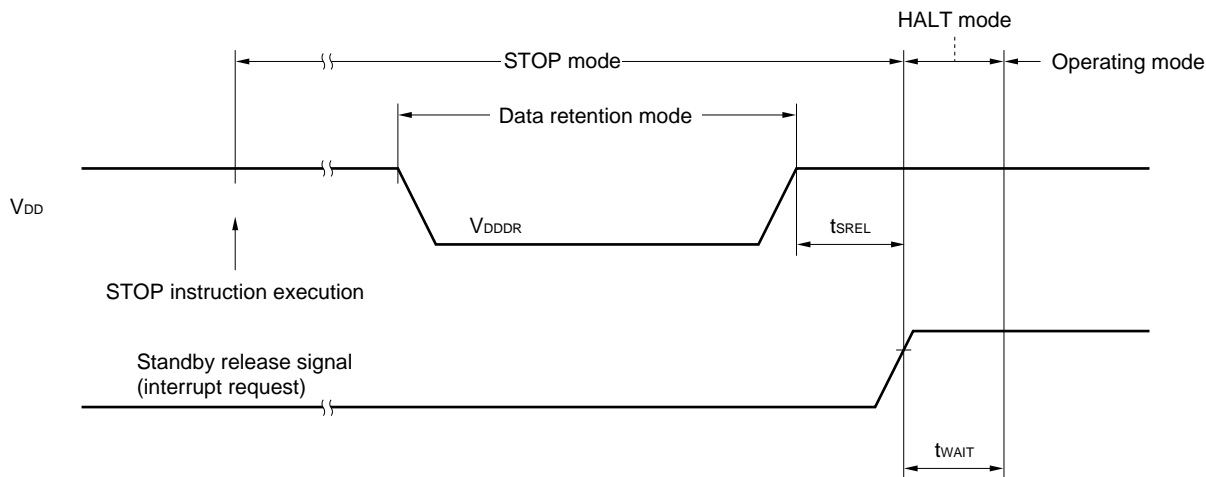



12. EXAMPLE OF RC OSCILLATOR FREQUENCY CHARACTERISTICS (REFERENCE VALUES)

f<sub>cc</sub> vs V<sub>DD</sub> (RC Oscillation, R = 11 kΩ, C = 22 pF)

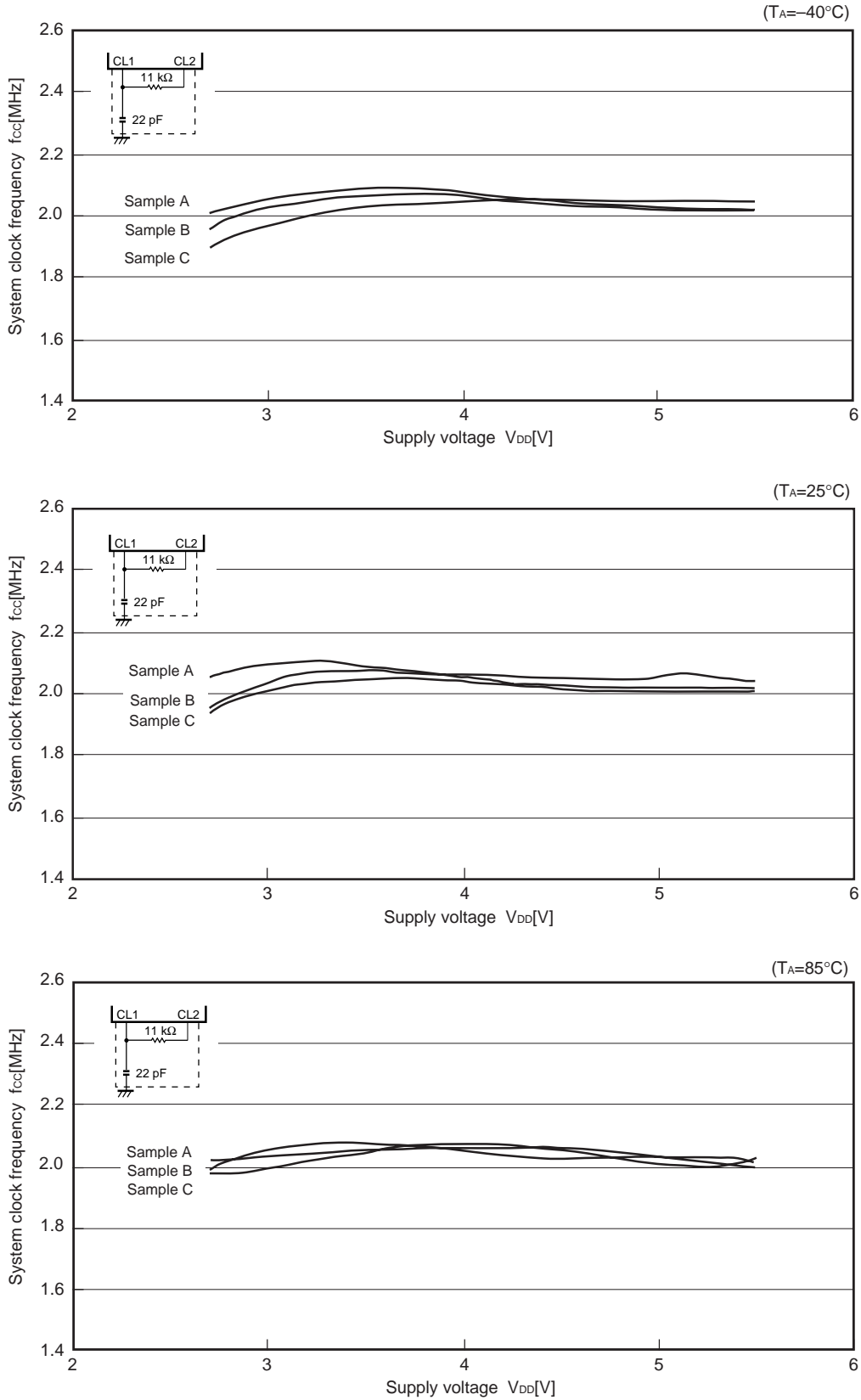

$f_{cc}$  vs  $V_{DD}$  (RC Oscillation,  $R = 4.7\text{ k}\Omega$ ,  $C = 22\text{ pF}$ )

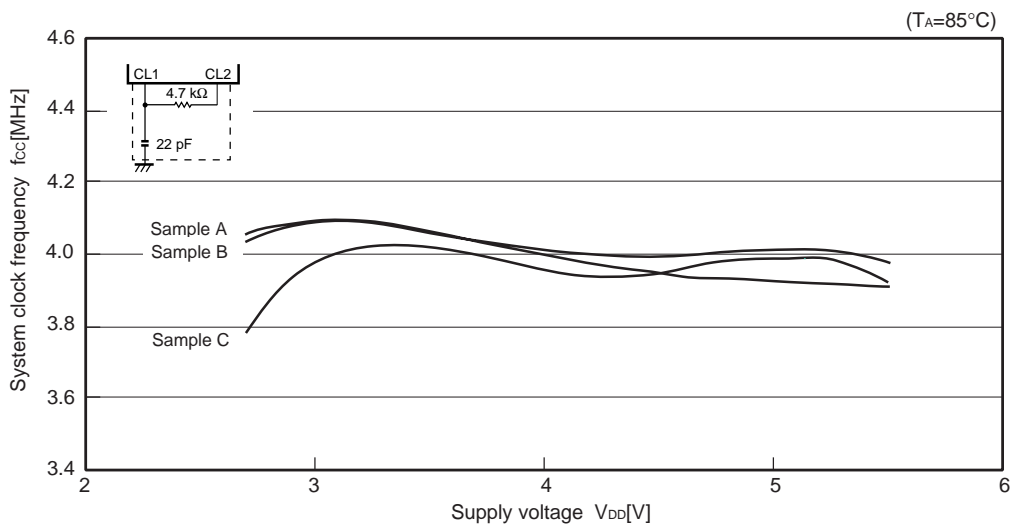
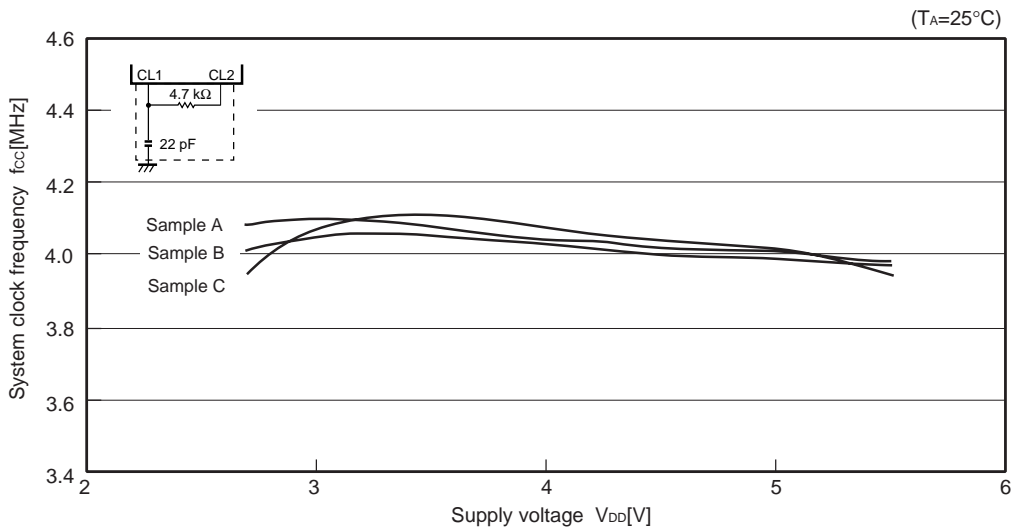
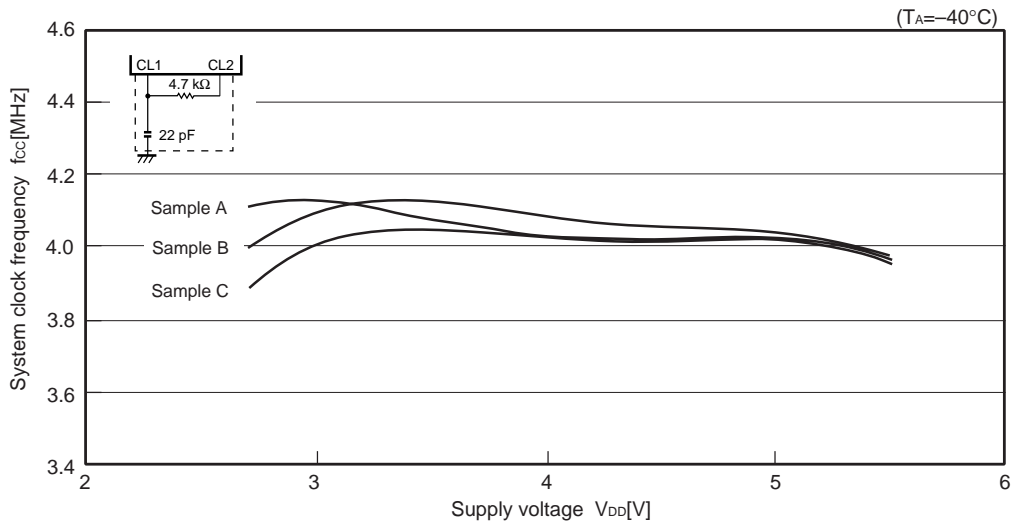

13. PACKAGE DRAWING

30-PIN PLASTIC SSOP (7.62 mm (300))

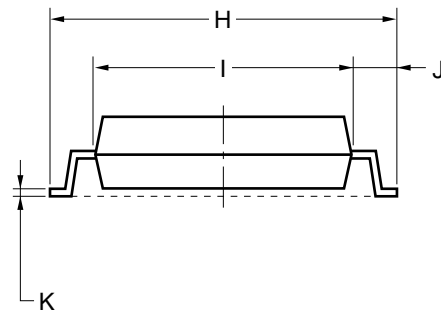
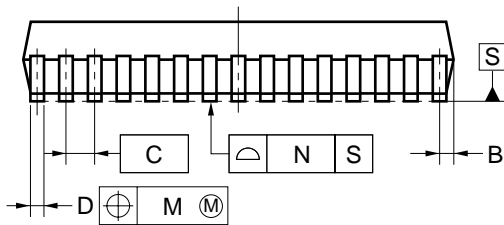
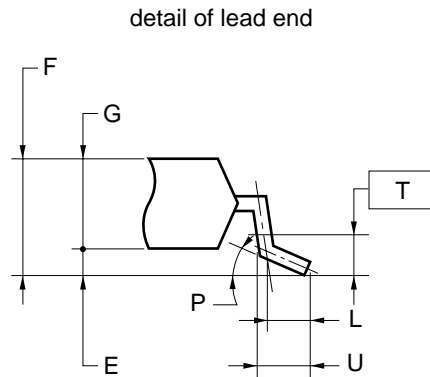
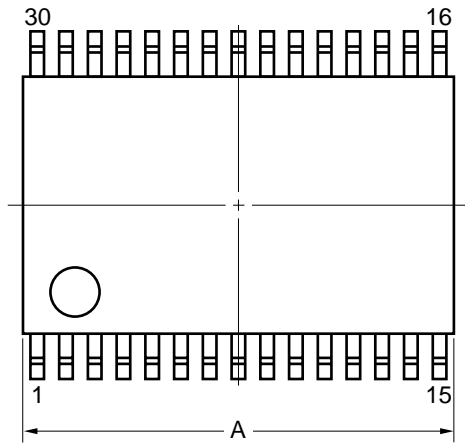

NOTE

Each lead centerline is located within 0.13 mm of its true position (T.P.) at maximum material condition.

ITEM	MILLIMETERS
A	9.85±0.15
B	0.45 MAX.
C	0.65 (T.P.)
D	0.24 <sup>+0.08</sup> <sub>-0.07</sub>
E	0.1±0.05
F	1.3±0.1
G	1.2
H	8.1±0.2
I	6.1±0.2
J	1.0±0.2
K	0.17±0.03
L	0.5
M	0.13
N	0.10
P	3° <sup>+5°</sup> <sub>-3°</sub>
T	0.25
U	0.6±0.15

S30MC-65-5A4-2

#### 14. RECOMMENDED SOLDERING CONDITIONS

The μPD78912xA, 78913xA, 78912xA(A), and 78913xA(A) should be soldered and mounted under the following recommended conditions.

For the details of the recommended soldering conditions, refer to the document **Semiconductor Device Mounting Technology Manual (C10535E)**. For soldering methods and conditions other than those recommended below, contact your NEC sales representative.

**Table 14-1. Surface Mounting Type Soldering Conditions**

- μPD789121AMC-xxx-5A4: 30-pin plastic SSOP (7.62 mm (300))
- μPD789122AMC-xxx-5A4: 30-pin plastic SSOP (7.62 mm (300))
- μPD789124AMC-xxx-5A4: 30-pin plastic SSOP (7.62 mm (300))
- μPD789131AMC-xxx-5A4: 30-pin plastic SSOP (7.62 mm (300))
- μPD789132AMC-xxx-5A4: 30-pin plastic SSOP (7.62 mm (300))
- μPD789134AMC-xxx-5A4: 30-pin plastic SSOP (7.62 mm (300))
- μPD789121AMC(A)-xxx-5A4: 30-pin plastic SSOP (7.62 mm (300))
- μPD789122AMC(A)-xxx-5A4: 30-pin plastic SSOP (7.62 mm (300))
- μPD789124AMC(A)-xxx-5A4: 30-pin plastic SSOP (7.62 mm (300))
- μPD789131AMC(A)-xxx-5A4: 30-pin plastic SSOP (7.62 mm (300))
- μPD789132AMC(A)-xxx-5A4: 30-pin plastic SSOP (7.62 mm (300))
- μPD789134AMC(A)-xxx-5A4: 30-pin plastic SSOP (7.62 mm (300))

Soldering Method	Soldering Conditions	Recommended Condition Symbol
Infrared reflow	Package peak temperature: 235°C, Time: 30 sec. Max. (at 210°C or higher), Count: three times or less	IR35-00-3
VPS	Package peak temperature: 215°C, Time: 40 sec. Max. (at 200°C or higher), Count: three times or less	VP15-00-3
Wave soldering	Solder bath temperature: 260°C Max., Time: 10 sec. Max., Count: once, Preheating temperature: 120°C Max. (package surface temperature)	WS60-00-1
Partial heating	Pin temperature: 300°C Max., Time: 3 sec. Max. (per pin row)	—

**Caution** Do not use different soldering methods together (except for partial heating).

## APPENDIX A DEVELOPMENT TOOLS

The following development tools are available for system development using the μPD78912xA, μPD78913xA, μPD78912xA(A), and μPD78913xA(A).

### Language Processing Software

RA78K0S <sup>Notes 1, 2, 3</sup>	Assembler package common to 78K/0S Series
CC78K0S <sup>Notes 1, 2, 3</sup>	C compiler package common to 78K/0S Series
DF789136 <sup>Notes 1, 2, 3</sup>	Device file for μPD789124A, 789134A Subseries

### Flash Memory Writing Tools

Flashpro III (Model number: FL-PR3 <sup>Note 4</sup> , PG-FP3)	Dedicated flash programmer for on-chip flash memory
FA-30MC <sup>Note 4</sup>	Flash memory writing adapter

### Debugging Tools (1/2)

IE-78K0S-NS In-circuit emulator	In-circuit emulator serves to debug hardware and software when developing application systems using a 78K/0S Series product. It supports the ID78K0S-NS integrated debugger. Used in combination with an AC adapter, emulation probe, and interface adapter connecting to the host machine.
IE-70000-MC-PS-B AC adapter	Adapter used to supply power from a power outlet of 100 V AC to 240 V AC.
IE-70000-98-IF-C Interface adapter	Adapter when PC-9800 series PC (except notebook type) is used as the IE-78K0S-NS host machine (C bus supported).
IE-70000-CD-IF-A PC card interface	PC card and interface cable when notebook PC is used as the IE-78K0S-NS host machine (PCMCIA socket supported).
IE-70000-PC-IF-C Interface adapter	Adapter when using an IBM PC/AT™ or compatible as the IE-78K0S-NS host machine.
IE-70000-PCI-IF Interface adapter	Adapter when using PC that includes a PCI bus as the IE-78K0S-NS host machine.
IE-789136-NS-EM1 Emulation board	Board for emulation of the peripheral hardware peculiar to a device. Used in combination with an in-circuit emulator.
NP-36GS <sup>Note 4</sup>	Board used to connect the in-circuit emulator to the target system. For a 30-pin plastic SSOP (MC-5A4 type), used in combination with NGS-30.
NGS-30 <sup>Note 4</sup> Conversion socket	Conversion socket used to connect the NP-36GS to the target system board designed to mount a 30-pin plastic SSOP (MC-5A4 type).

- Notes**
1. PC-9800 series (Japanese Windows™) based
  2. IBM PC/AT or compatibles (Japanese/English Windows) based
  3. HP9000 series 700™ (HP-UX™), SPARCstation™ (SunOS™, Solaris™), or NEWS™ (NEWS-OS™) based.
  4. Products made by Naito Densai Machida Mfg. Co., Ltd. (Phone: +81-44-822-3813).

**Remark** RA78K0S, CC78K0S, and SM78K0S are used in combination with the DF789136.

**Debugging Tools (2/2)**

SM78K0S <sup>Notes 1, 2</sup>	System simulator common to 78K/0S Series
ID78K0S-NS <sup>Notes 1, 2</sup>	Integrated debugger common to 78K/0S Series
DF789136 <sup>Notes 1, 2</sup>	Device file for $\mu$ PD789124A, 789134A Subseries

**Real-time OS**

MX78K0S <sup>Notes 1, 2</sup>	OS for 78K/0S Series
-------------------------------	----------------------

- Notes**
1. PC-9800 series (Japanese Windows) based.
  2. IBM PC/AT or compatibles (Japanese/English Windows) based.

**APPENDIX B RELATED DOCUMENTS**

**Documents Related to Devices**

Document Name	Document No.	
	Japanese	English
μPD789121A, 122A, 124A, 131A, 132A, 134A, 121A(A), 122A(A), 124A(A), 131A(A), 132A(A), 134A(A) Data Sheet	U14678J	This manual
μPD78F9136A Data Sheet	To be prepared	To be prepared
μPD789104A, 789114A, 789124A, 789134A Subseries User's Manual	To be prepared	To be prepared
78K/0S Series User's Manual Instruction	U11047J	U11047E
78K/0, 78K/0S Series Application Note Flash Memory Write	U14458J	U14458E

**Documents Related to Development Tools (User's Manuals)**

Document Name	Document No.		
	Japanese	English	
RA78K0S Assembler Package	Operation	U11622J	U11622E
	Assembly Language	U11599J	U11599E
	Structured Assembly Language	U11623J	U11623E
CC78K0S C Compiler	Operation	U11816J	U11816E
	Language	U11817J	U11817E
SM78K0S System Simulator Windows Based	Reference	U11489J	U11489E
SM78K Series System Simulator	External Parts User Open Interface Specifications	U10092J	U10092E
ID78K0S-NS Integrated Debugger Windows Based	Reference	U12901J	U12901E
IE-78K0S-NS In-circuit Emulator		U13549J	U13549E
IE-789136-NS-EM1 Emulation Board		U14363J	U14363E

**Documents Related to Embedded Software (User's Manuals)**

Document Name	Document No.		
	Japanese	English	
78K/0S Series OS MX78K0S	Fundamental	U12938J	U12938E

**Caution** The related documents listed above are subject to change without notice. Be sure to use the latest version of each document for designing.

**Other Related Documents**

Document Name	Document No.	
	Japanese	English
SEMICONDUCTORS SELECTION GUIDE Products & Packages (CD-ROM)	X13769X	
Semiconductor Device Mounting Technology Manual	C10535J	C10535E
Quality Grades on NEC Semiconductor Devices	C11531J	C11531E
NEC Semiconductor Device Reliability/Quality Control System	C10983J	C10983E
Guide to Prevent Damage for Semiconductor Devices by Electrostatic Discharge (ESD)	C11892J	C11892E
Guide to Microcomputer-Related Products by Third Party	U11416J	-

**Caution** The related documents listed above are subject to change without notice. Be sure to use the latest version of each document for designing.



[MEMO]

**NOTES FOR CMOS DEVICES****① PRECAUTION AGAINST ESD FOR SEMICONDUCTORS**

Note:

Strong electric field, when exposed to a MOS device, can cause destruction of the gate oxide and ultimately degrade the device operation. Steps must be taken to stop generation of static electricity as much as possible, and quickly dissipate it once, when it has occurred. Environmental control must be adequate. When it is dry, humidifier should be used. It is recommended to avoid using insulators that easily build static electricity. Semiconductor devices must be stored and transported in an anti-static container, static shielding bag or conductive material. All test and measurement tools including work bench and floor should be grounded. The operator should be grounded using wrist strap. Semiconductor devices must not be touched with bare hands. Similar precautions need to be taken for PW boards with semiconductor devices on it.

**② HANDLING OF UNUSED INPUT PINS FOR CMOS**

Note:

No connection for CMOS device inputs can be cause of malfunction. If no connection is provided to the input pins, it is possible that an internal input level may be generated due to noise, etc., hence causing malfunction. CMOS devices behave differently than Bipolar or NMOS devices. Input levels of CMOS devices must be fixed high or low by using a pull-up or pull-down circuitry. Each unused pin should be connected to  $V_{DD}$  or GND with a resistor, if it is considered to have a possibility of being an output pin. All handling related to the unused pins must be judged device by device and related specifications governing the devices.

**③ STATUS BEFORE INITIALIZATION OF MOS DEVICES**

Note:

Power-on does not necessarily define initial status of MOS device. Production process of MOS does not define the initial operation status of the device. Immediately after the power source is turned ON, the devices with reset function have not yet been initialized. Hence, power-on does not guarantee out-pin levels, I/O settings or contents of registers. Device is not initialized until the reset signal is received. Reset operation must be executed immediately after power-on for devices having reset function.

EEPROM is a trademark of NEC Corporation.

Windows is either a registered trademark or a trademark of Microsoft Corporation in the United States and/or other countries.

PC/AT is a trademark of International Business Machines Corporation.

HP9000 series 700 and HP-UX are trademarks of Hewlett-Packard Company.

SPARCstation is a trademark of SPARC International, Inc.

Solaris and SunOS are trademarks of Sun Microsystems, Inc.

NEWS and NEWS-OS are trademarks of SONY Corporation.

## Regional Information

Some information contained in this document may vary from country to country. Before using any NEC product in your application, please contact the NEC office in your country to obtain a list of authorized representatives and distributors. They will verify:

- Device availability
- Ordering information
- Product release schedule
- Availability of related technical literature
- Development environment specifications (for example, specifications for third-party tools and components, host computers, power plugs, AC supply voltages, and so forth)
- Network requirements

In addition, trademarks, registered trademarks, export restrictions, and other legal issues may also vary from country to country.

**NEC Electronics Inc. (U.S.)**

Santa Clara, California  
 Tel: 408-588-6000  
 800-366-9782  
 Fax: 408-588-6130  
 800-729-9288

**NEC Electronics (Germany) GmbH**

Duesseldorf, Germany  
 Tel: 0211-65 03 02  
 Fax: 0211-65 03 490

**NEC Electronics (UK) Ltd.**

Milton Keynes, UK  
 Tel: 01908-691-133  
 Fax: 01908-670-290

**NEC Electronics Italiana s.r.l.**

Milano, Italy  
 Tel: 02-66 75 41  
 Fax: 02-66 75 42 99

**NEC Electronics (Germany) GmbH**

Benelux Office  
 Eindhoven, The Netherlands  
 Tel: 040-2445845  
 Fax: 040-2444580

**NEC Electronics (France) S.A.**

Velizy-Villacoublay, France  
 Tel: 01-30-67 58 00  
 Fax: 01-30-67 58 99

**NEC Electronics (France) S.A.**

Spain Office  
 Madrid, Spain  
 Tel: 91-504-2787  
 Fax: 91-504-2860

**NEC Electronics (Germany) GmbH**

Scandinavia Office  
 Taebly, Sweden  
 Tel: 08-63 80 820  
 Fax: 08-63 80 388

**NEC Electronics Hong Kong Ltd.**

Hong Kong  
 Tel: 2886-9318  
 Fax: 2886-9022/9044

**NEC Electronics Hong Kong Ltd.**

Seoul Branch  
 Seoul, Korea  
 Tel: 02-528-0303  
 Fax: 02-528-4411

**NEC Electronics Singapore Pte. Ltd.**

United Square, Singapore 1130  
 Tel: 65-253-8311  
 Fax: 65-250-3583

**NEC Electronics Taiwan Ltd.**

Taipei, Taiwan  
 Tel: 02-2719-2377  
 Fax: 02-2719-5951

**NEC do Brasil S.A.**

Electron Devices Division  
 Rodovia Presidente Dutra, Km 214  
 07210-902-Guarulhos-SP Brasil  
 Tel: 55-11-6465-6810  
 Fax: 55-11-6465-6829

J99.1

**The related documents indicated in this publication may include preliminary versions. However, preliminary versions are not marked as such.**

The export of this product from Japan is regulated by the Japanese government. To export this product may be prohibited without governmental license, the need for which must be judged by the customer. The export or re-export of this product from a country other than Japan may also be prohibited without a license from that country. Please call an NEC sales representative.

- **The information in this document is subject to change without notice. Before using this document, please confirm that this is the latest version.**
  - No part of this document may be copied or reproduced in any form or by any means without the prior written consent of NEC Corporation. NEC Corporation assumes no responsibility for any errors which may appear in this document.
  - NEC Corporation does not assume any liability for infringement of patents, copyrights or other intellectual property rights of third parties by or arising from use of a device described herein or any other liability arising from use of such device. No license, either express, implied or otherwise, is granted under any patents, copyrights or other intellectual property rights of NEC Corporation or others.
  - Descriptions of circuits, software, and other related information in this document are provided for illustrative purposes in semiconductor product operation and application examples. The incorporation of these circuits, software, and information in the design of the customer's equipment shall be done under the full responsibility of the customer. NEC Corporation assumes no responsibility for any losses incurred by the customer or third parties arising from the use of these circuits, software, and information.
  - While NEC Corporation has been making continuous effort to enhance the reliability of its semiconductor devices, the possibility of defects cannot be eliminated entirely. To minimize risks of damage or injury to persons or property arising from a defect in an NEC semiconductor device, customers must incorporate sufficient safety measures in its design, such as redundancy, fire-containment, and anti-failure features.
  - NEC devices are classified into the following three quality grades:  
"Standard", "Special", and "Specific". The Specific quality grade applies only to devices developed based on a customer designated "quality assurance program" for a specific application. The recommended applications of a device depend on its quality grade, as indicated below. Customers must check the quality grade of each device before using it in a particular application.
    - Standard: Computers, office equipment, communications equipment, test and measurement equipment, audio and visual equipment, home electronic appliances, machine tools, personal electronic equipment and industrial robots
    - Special: Transportation equipment (automobiles, trains, ships, etc.), traffic control systems, anti-disaster systems, anti-crime systems, safety equipment and medical equipment (not specifically designed for life support)
    - Specific: Aircraft, aerospace equipment, submersible repeaters, nuclear reactor control systems, life support systems or medical equipment for life support, etc.
- The quality grade of NEC devices is "Standard" unless otherwise specified in NEC's Data Sheets or Data Books. If customers intend to use NEC devices for applications other than those specified for Standard quality grade, they should contact an NEC sales representative in advance.