

## 16/8-BIT SINGLE-CHIP MICROCONTROLLERS

### DESCRIPTION

The  $\mu$ PD78F4218 is a product in the  $\mu$ PD784218 subseries in the 78K/IV series.

The  $\mu$ PD78F4218 has a flash memory in the place of the internal ROM of the  $\mu$ PD784218. Data can be written to or erased from the flash memory of the  $\mu$ PD78F4218 with the microcontroller mounted on a printed wiring board.

**The functions are explained in detail in the following user's manuals. Be sure to read this manual when designing your system.**

$\mu$ PD784218, 784218Y Subseries User's Manual - Hardware: Planned  
78K/IV Series User's Manual - Instruction : U10905E

### FEATURES

- Pin-compatible with mask ROM model (except  $V_{PP}$  pin)
- Flash memory: 256K bytes
- Internal RAM: 12800 bytes
- Same operating voltage as mask ROM model:  $V_{DD} = 1.8$  to  $5.5$  V

### ORDERING INFORMATION

Part Number	Package
$\mu$ PD78F4218GC-7EA	100-pin plastic QFP (fine pitch) (14 × 14 mm)
$\mu$ PD78F4218GF-3BA	100-pin plastic QFP (14 × 20 mm)

The information contained in this document is being issued in advance of the production cycle for the device. The parameters for the device may change before final production or NEC Corporation, at its own discretion, may withdraw the device prior to its production.

78K/IV Series Product Development

: Under mass production

: Under development

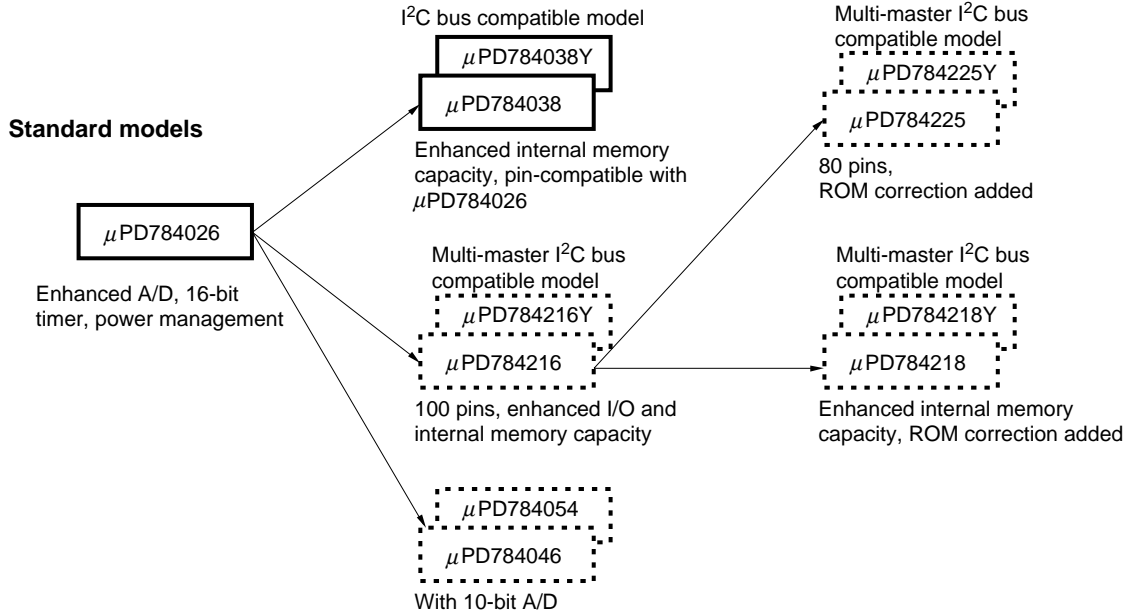

**ASSP models**

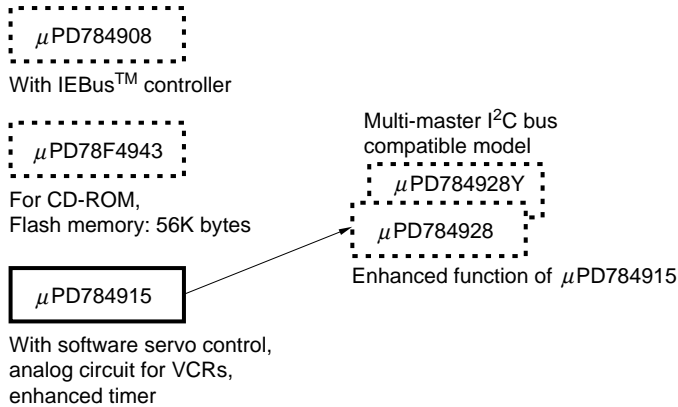

FUNCTIONS (1/2)

Item		Function	
Number of basic instructions (mnemonics)		113	
General-purpose register		8 bits × 16 registers × 8 banks, or 16 bits × 8 registers × 8 banks (memory mapping)	
Minimum instruction execution time		<ul style="list-style-type: none"> <li>• 160 ns/320 ns/640 ns/1280 ns/2560 ns (main system clock: f<sub>xx</sub> = 12.5 MHz)</li> <li>• 61 μs (subsystem clock: f<sub>xx</sub> = 32.768 KHz)</li> </ul>	
Internal memory	Flash memory	256K bytes	
	RAM	12800 bytes	
Memory space		1 MB with program and data spaces combined	
I/O port	Total	86	
	CMOS Input	8	
	CMOS I/O	72	
	N-ch open-drain I/O	6	
Pins with ancillary functions <sup>Note</sup>	Pins with pull-up resistor	70	
	LEDs direct drive output	22	
	Medium voltage pin	6	
Real-time output port		4 bits × 2, or 8 bits × 1	
Timer/counter		16-bit timer/counter : timer register × 1 Capture/compare register × 2	Pulse output • PWM/PPG output • Square wave output • One-shot pulse output
		8-bit timer/counter 1 : timer register × 1 Compare register × 1	Pulse output • PWM output • Square wave output
		8-bit timer/counter 2 : timer register × 1 Compare register × 1	Pulse output • PWM output • Square wave output
		8-bit timer/counter 5 : timer register × 1 Compare register × 1	Pulse output • PWM output • Square wave output
		8-bit timer/counter 6 : timer register × 1 Compare register × 1	Pulse output • PWM output • Square wave output
		8-bit timer/counter 7 : timer register × 1 Compare register × 1	Pulse output • PWM output • Square wave output
		8-bit timer/counter 8 : timer register × 1 Compare register × 1	Pulse output • PWM output • Square wave output

**Note** The pins with ancillary functions are included in the I/O pins.

## FUNCTIONS (2/2)

Item		Function
Serial interface		<ul style="list-style-type: none"> <li>• UART/IOE (3-wire serial I/O): 2 channels (on-chip baud rate generator)</li> <li>• CSI (3-wire serial I/O): 1 channel</li> </ul>
A/D converter		8-bit resolution $\times$ 8 channels
D/A converter		8-bit resolution $\times$ 2 channels
Clock output		Selectable from $f_{xx}$ , $f_{xx}/2$ , $f_{xx}/2^2$ , $f_{xx}/2^3$ , $f_{xx}/2^4$ , $f_{xx}/2^5$ , $f_{xx}/2^6$ , $f_{xx}/2^7$ , $f_{XT}$
Buzzer output		Selectable from $f_{xx}/2^{10}$ , $f_{xx}/2^{11}$ , $f_{xx}/2^{12}$ , $f_{xx}/2^{13}$
Watch timer		1 channel
Watchdog timer		1 channel
Standby		<ul style="list-style-type: none"> <li>• HALT/STOP/IDLE mode</li> <li>• In power-saving mode (with subsystem clock): HALT/IDLE mode</li> </ul>
Interrupt	Hardware	29 (internal: 20, external: 9)
	Software	BRK instruction, BRKCS instruction, operand error
	Non-maskable	Internal: 1, external: 1
	Maskable	Internal: 19, external: 8
		<ul style="list-style-type: none"> <li>• 4 programmable priority levels</li> <li>• 3 service modes: vectored interrupt/macro service/context switching</li> </ul>
Supply voltage		$V_{DD} = 1.8$ to $5.5$ V
Package		<ul style="list-style-type: none"> <li>• 100-pin plastic QFP (fine pitch) (<math>14 \times 14</math> mm)</li> <li>• 100-pin plastic QFP (<math>14 \times 20</math> mm)</li> </ul>

**CONTENTS**

**1. DIFFERENCES AMONG MODELS IN μPD784218 SUBSERIES ..... 6**

**2. DIFFERENCES BETWEEN μPD78F4218 AND μPD78F4216 ..... 6**

**3. PIN CONFIGURATION (Top View) ..... 7**

**4. BLOCK DIAGRAM ..... 10**

**5. PIN FUNCTION ..... 11**

**5.1 Port Pins ..... 11**

**5.2 Pins Other Than Port Pins ..... 13**

**5.3 I/O Circuit Type of Respective Pins and Recommended Connections of Unused Pins ..... 15**

**6. INTERNAL MEMORY SIZE SELECT REGISTER (IMS) ..... 18**

**7. PROGRAMMING FLASH MEMORY ..... 19**

**7.1 Selecting Communication Mode ..... 19**

**7.2 Flash Memory Programming Function ..... 20**

**7.3 Connecting Flashpro II ..... 20**

**8. PACKAGE DRAWINGS ..... 21**

**APPENDIX A. DEVELOPMENT TOOLS ..... 23**

**APPENDIX B. RELATED DOCUMENTS ..... 25**

**1. DIFFERENCES AMONG MODELS IN μPD784218 SUBSERIES**

The only difference between the μPD784217 and 784218 lies in the internal memory capacity.

The μPD78F4218 is provided with a 256-KB flash memory instead of the mask ROM of the above models. These differences are summarized in Table 1-1.

**Table 1-1. Differences among Models in μPD784218 Subseries**

Part Number Item	μPD784217	μPD784218	μPD78F4218
Internal ROM	192K bytes (mask ROM)	256K bytes (mask ROM)	256K bytes (Flash memory)
Internal RAM	12800 bytes		
Internal memory size switching register (IMS)	None		Provided
V <sub>PP</sub> pin	None		Provided

**2. DIFFERENCES BETWEEN μPD78F4218 AND μPD78F4216**

The differences between μPD78F4218 and μPD78F4216 are shown in Table 2-1.

**Table 2-1. Differences between μPD78F4218 and μPD78F4216**

Part Number Item	μPD78F4218	μPD78F4216
Flash memory	256K bytes	128K Bytes
Internal RAM	12800 bytes	8192 bytes
ROM correction	Provided	None
External access status function	Provided	None

### 3. PIN CONFIGURATION (Top View)

- 100-pin plastic QFP (fine pitch) (14 × 14 mm)  
μPD78F4218GC-7EA

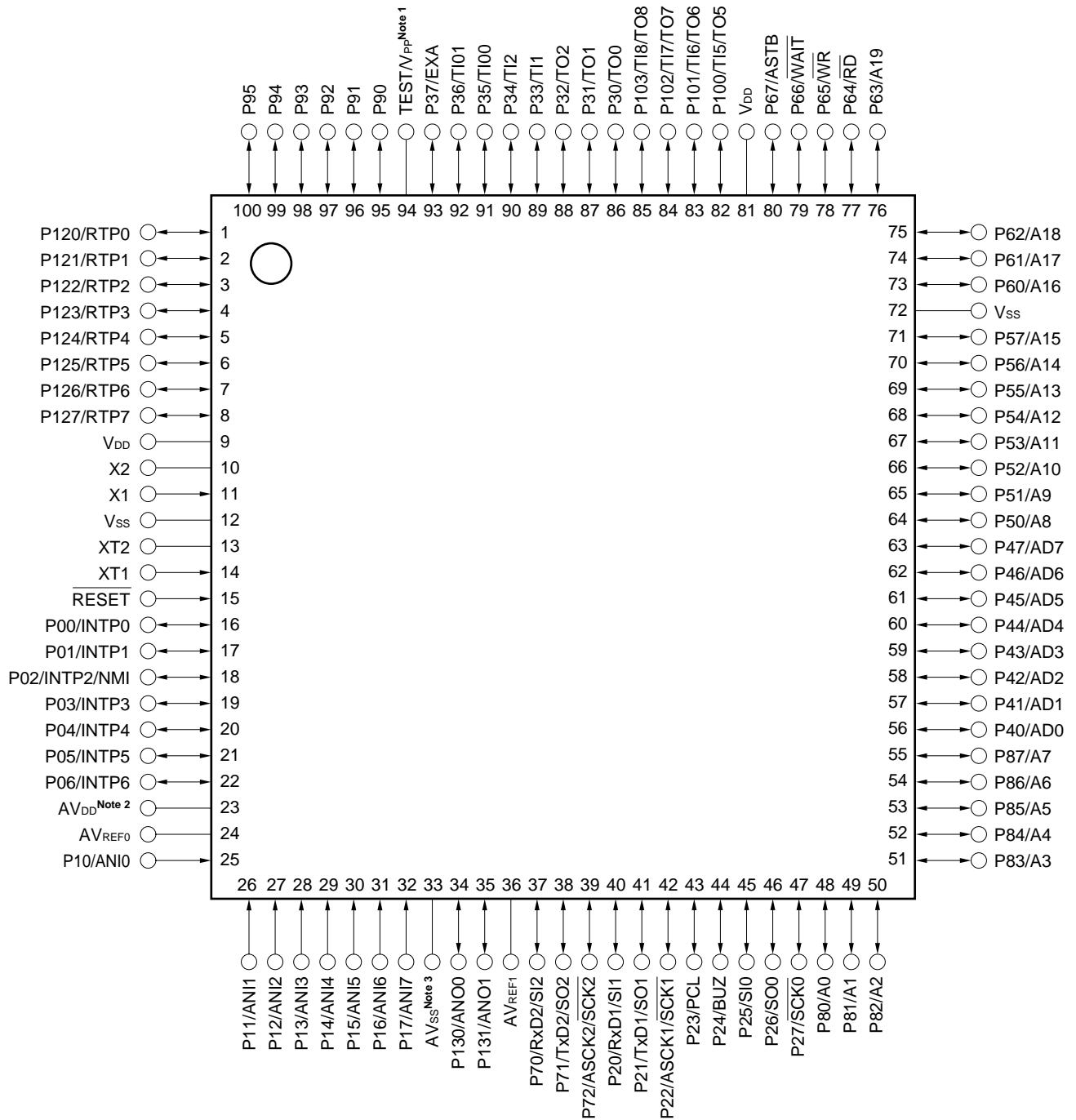

- Notes**
1. Directly connect the TEST/V<sub>PP</sub> pin to V<sub>SS</sub> in normal operation mode.
  2. Connect the AV<sub>DD</sub> pin to V<sub>DD</sub>.
  3. Connect the AV<sub>SS</sub> pin to V<sub>SS</sub>.

- 100-pin plastic QFP (14 × 20 mm)  
μPD78F4218GF-3BA

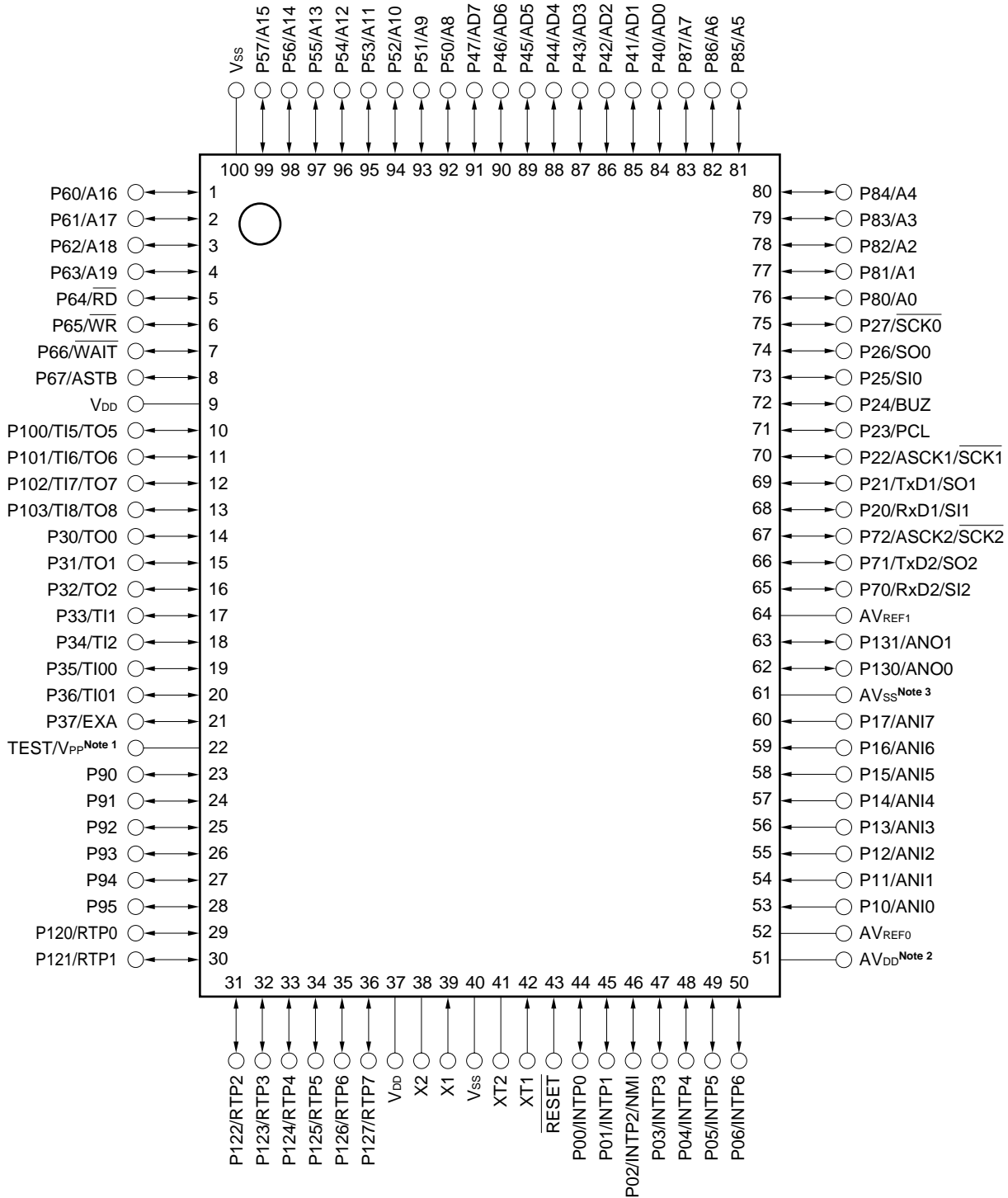

- Notes**
1. Directly connect the TEST/V<sub>PP</sub> pin to V<sub>SS</sub> in normal operation mode.
  2. Connect the AV<sub>DD</sub> pin to V<sub>DD</sub>.
  3. Connect the AV<sub>SS</sub> pin to V<sub>SS</sub>.



A0-A19	: Address Bus	P100-P103	: Port10
AD0-AD7	: Address/Data Bus	P120-P127	: Port12
ANI0-ANI7	: Analog Input	P130, P131	: Port13
ANO0, ANO1	: Analog Output	PCL	: Programmable Clock
ASCK1, ASCK2	: Asynchronous Serial Clock	$\overline{RD}$	: Read Strobe
ASTB	: Address Strobe	$\overline{RESET}$	: Reset
AV <sub>DD</sub>	: Analog Power Supply	RTP0-RTP7	: Real-time Output Port
AV <sub>REF0</sub> , AV <sub>REF1</sub>	: Analog Reference Voltage	RxD1, RxD2	: Receive Data
AV <sub>SS</sub>	: Analog Ground	$\overline{SCK0}$ - $\overline{SCK2}$	: Serial Clock
BUZ	: Buzzer Clock	SI0-SI2	: Serial Input
EXA	: External Access Status Output	SO0-SO2	: Serial Output
INTP0-INTP6	: Interrupt from Peripherals	TEST	: Test
NMI	: Non-maskable Interrupt	TI00, TI01,	
P00-P06	: Port0	TI1, TI2, TI5-TI8	: Timer Input
P10-P17	: Port1	TO0-TO2, TO5-TO8	: Timer Output
P20-P27	: Port2	TxD1, TxD2	: Transmit Data
P30-P37	: Port3	V <sub>DD</sub>	: Power Supply
P40-P47	: Port4	V <sub>PP</sub>	: Programming Power Supply
P50-P57	: Port5	V <sub>SS</sub>	: Ground
P60-P67	: Port6	$\overline{WAIT}$	: Wait
P70-P72	: Port7	$\overline{WR}$	: Write Strobe
P80-P87	: Port8	X1, X2	: Crystal (Main System Clock)
P90-P95	: Port9	XT1, XT2	: Crystal (Subsystem Clock)

4. BLOCK DIAGRAM

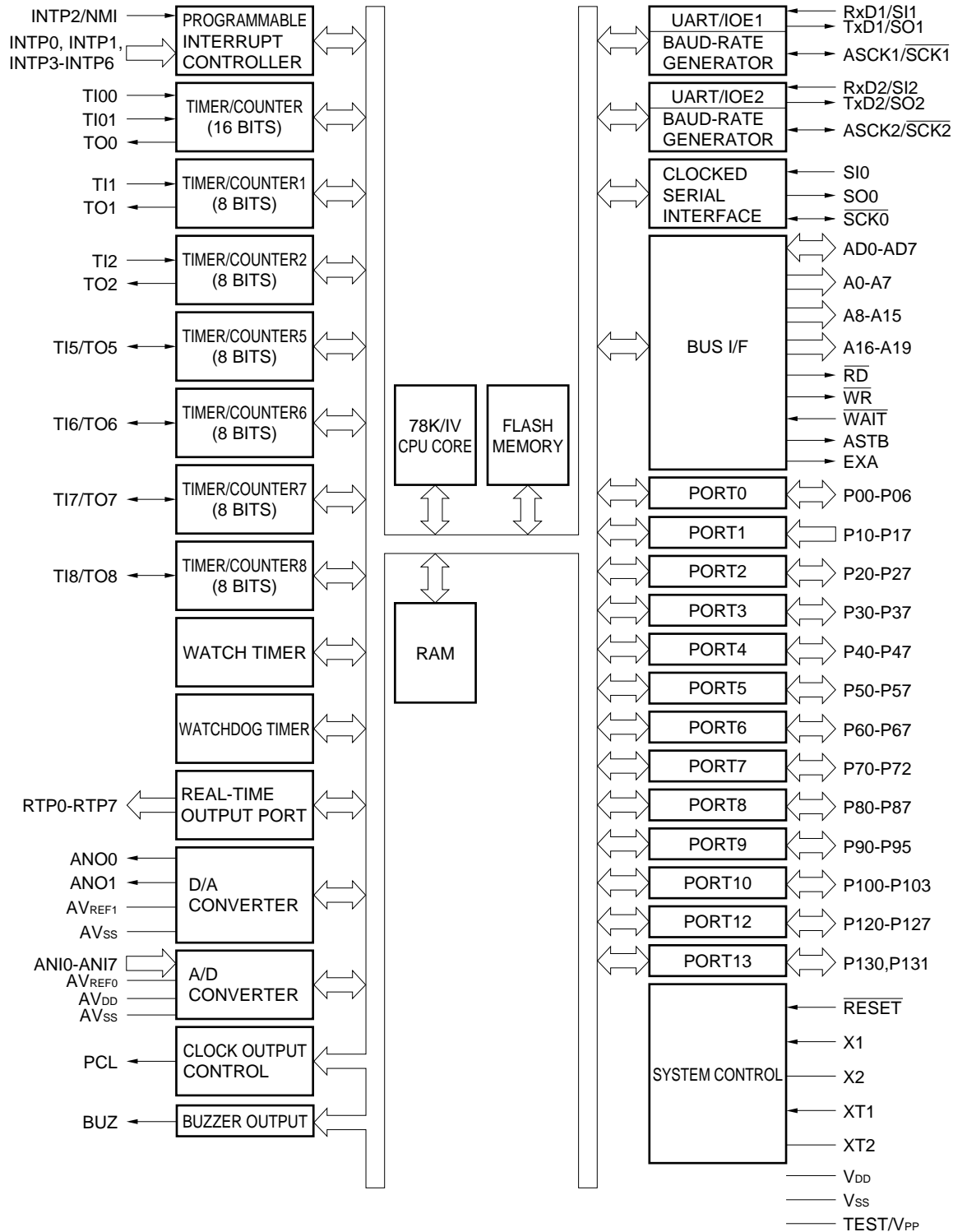

5. PIN FUNCTION

5.1 Port Pins (1/2)

Pin Name	I/O	Alternate Function	Function
P00	I/O	INTP0	Port 0 (P0): <ul style="list-style-type: none"> <li>• 7-bit I/O port</li> <li>• Can be set in input or output mode bit-wise.</li> <li>• Pins set in input mode can be connected to internal pull-up resistors by software bit-wise.</li> </ul>
P01		INTP1	
P02		INTP2/NMI	
P03		INTP3	
P04		INTP4	
P05		INTP5	
P06		INTP6	
P10-P17	Input	ANI0-ANI7	Port 1 (P1): <ul style="list-style-type: none"> <li>• 8-bit input port</li> </ul>
P20	I/O	RxD1/SI1	Port 2 (P2): <ul style="list-style-type: none"> <li>• 8-bit I/O port</li> <li>• Can be set in input or output mode bit-wise.</li> <li>• Pins set in input mode can be connected to internal pull-up resistors by software bit-wise.</li> </ul>
P21		TxD1/SO1	
P22		ASCK1/SCK1	
P23		PCL	
P24		BUZ	
P25		SI0	
P26		SO0	
P27		SCK0	
P30	I/O	TO0	Port 3 (P3): <ul style="list-style-type: none"> <li>• 8-bit I/O port</li> <li>• Can be set in input or output mode bit-wise.</li> <li>• Pins set in input mode can be connected to internal pull-up resistors by software bit-wise.</li> </ul>
P31		TO1	
P32		TO2	
P33		TI1	
P34		TI2	
P35		TI00	
P36		TI01	
P37		EXA	
P40-P47	I/O	AD0-AD7	Port 4 (P4): <ul style="list-style-type: none"> <li>• 8-bit I/O port</li> <li>• Can be set in input or output mode bit-wise.</li> <li>• All pins set in input mode can be connected to internal pull-up resistors by software.</li> <li>• Can drive LEDs.</li> </ul>
P50-P57	I/O	A8-A15	Port 5 (P5): <ul style="list-style-type: none"> <li>• 8-bit I/O port</li> <li>• Can be set in input or output mode bit-wise.</li> <li>• All pins set in input mode can be connected to internal pull-up resistors by software.</li> <li>• Can drive LEDs.</li> </ul>

5.1 Port Pins (2/2)

Pin Name	I/O	Alternate Function	Function
P60	I/O	A16	Port 6 (P6): <ul style="list-style-type: none"> <li>• 8-bit I/O port</li> <li>• Can be set in input or output mode bit-wise.</li> <li>• All pins set in input mode can be connected to internal pull-up resistors by software.</li> </ul>
P61		A17	
P62		A18	
P64		$\overline{\text{RD}}$	
P65		$\overline{\text{WR}}$	
P66		$\overline{\text{WAIT}}$	
P67		ASTB	
P70	I/O	RxD2/SI2	Port 7 (P7): <ul style="list-style-type: none"> <li>• 3-bit I/O port</li> <li>• Can be set in input or output mode bit-wise.</li> <li>• Pins set in input mode can be connected to internal pull-up resistor by software bit-wise.</li> </ul>
P71		TxD2/SO2	
P72		ASCK2/ $\overline{\text{SCK2}}$	
P80-P87	I/O	A0-A7	Port 8 (P8): <ul style="list-style-type: none"> <li>• 8-bit I/O port</li> <li>• Can be set in input or output mode bit-wise.</li> <li>• Pins set in input mode can be connected to internal pull-up resistor by software bit-wise.</li> <li>• Interrupt control flag (KRIF) is set to 1 when falling edge is detected at a pin of this port.</li> </ul>
P90-P95	I/O	—	Port 9 (P9): <ul style="list-style-type: none"> <li>• N-ch open-drain medium-voltage I/O port</li> <li>• 6-bit I/O port</li> <li>• Can be set in input or output mode bit-wise.</li> <li>• Can directly drive LEDs.</li> </ul>
P100	I/O	TI5/TO5	Port 10 (P10): <ul style="list-style-type: none"> <li>• 4-bit I/O port</li> <li>• Can be set in input or output mode bit-wise.</li> <li>• Pins set in input mode can be connected to internal pull-up resistor by software bit-wise.</li> </ul>
P101		TI6/TO6	
P102		TI7/TO7	
P103		TI8/TO8	
P120-P127	I/O	RTP0-RTP7	Port 12 (P12): <ul style="list-style-type: none"> <li>• 8-bit I/O port</li> <li>• Can be set in input or output mode bit-wise.</li> <li>• Pins set in input mode can be connected to internal pull-up resistor by software bit-wise.</li> </ul>
P130, P131	I/O	ANO0, ANO1	Port 13 (P13): <ul style="list-style-type: none"> <li>• 2-bit I/O port</li> <li>• Can be set in input or output mode bit-wise.</li> </ul>

5.2 Pins Other Than Port Pins (1/2)

Pin Name	I/O	Alternate Function	Function
TI00	Input	P35	External count clock input to 16-bit timer register
TI01		P36	Capture trigger signal input to capture/compare register 00
TI1		P33	External count clock input to 8-bit timer register 1
TI2		P34	External count clock input to 8-bit timer register 2
TI5		P100/TO5	External count clock input to 8-bit timer register 5
TI6		P101/TO6	External count clock input to 8-bit timer register 6
TI7		P102/TO7	External count clock input to 8-bit timer register 7
TI8		P103/TO8	External count clock input to 8-bit timer register 8
TO0	Output	P30	16-bit timer output (shared by 14-bit PWM output)
TO1		P31	8-bit timer output (shared by 8-bit PWM output)
TO2		P32	
TO5		P100/TO5	
TO6		P101/TO6	
TO7		P102/TO7	
TO8		P103/TO8	
RxD1	Input	P20/SI1	Serial data input (UART1)
RxD2		P70/SI2	Serial data input (UART2)
TxD1	Output	P21/SO1	Serial data output (UART1)
TxD2		P71/SO2	Serial data output (UART2)
ASCK1	Input	P22/ $\overline{\text{SCK1}}$	Baud rate clock input (UART1)
ASCK2		P72/ $\overline{\text{SCK2}}$	Baud rate clock input (UART2)
SI0	Input	P25	Serial data input (3-wire serial clock I/O0)
SI1		P20/RxD1	Serial data input (3-wire serial clock I/O1)
SI2		P70/RxD2	Serial data input (3-wire serial clock I/O2)
SO0	Output	P26	Serial data output (3-wire serial I/O0)
SO1		P21/TxD1	Serial data output (3-wire serial I/O1)
SO2		P71/TxD2	Serial data output (3-wire serial I/O2)
$\overline{\text{SCK0}}$	I/O	P27/SCL0	Serial clock input/output (3-wire serial I/O0)
$\overline{\text{SCK1}}$		P22/ASCK1	Serial clock input/output (3-wire serial I/O1)
$\overline{\text{SCK2}}$		P72/ASCK2	Serial clock input/output (3-wire serial I/O2)
NMI	Input	P02/INTP2	Non-maskable interrupt request input
INTP0		P00	External interrupt request input
INTP1		P01	
INTP2		P02/NMI	
INTP3		P03	
INTP4		P04	
INTP5		P05	
INTP6		P06	

5.2 Pins Other Than Port Pins (2/2)

Pin Name	I/O	Alternate Function	Function	
PCL	Output	P23	Clock output (for trimming main system clock and subsystem clock)	
BUZ	Output	P24	Buzzer output	
RTP0-RTP7	Output	P120-P127	Real-time output port that outputs data in synchronization with trigger	
AD0-AD7	I/O	P40-P47	Low-order address/data bus when external memory is connected	
A0-A7	Output	P80-P87	Low-order address bus when external memory is connected	
A8-A15		P50-P57	Middle-order address bus when external memory is connected	
A16-A19		P60-P63	High-order address bus when external memory is connected	
$\overline{RD}$	Output	P64	Strobe signal output for read operation of external memory	
$\overline{WR}$		P65	Strobe signal output for write operation of external memory	
$\overline{WAIT}$	Input	P66	To insert wait state(s) when external memory is accessed	
ASTB	Output	P67	Strobe output to externally latch address information output to ports 4 through 6 and port 8 to access external memory	
EXA	Output	P37	Status signal output when external memory is accessed	
$\overline{RESET}$	Input	—	System reset input	
X1	Input	—	To connect main system clock oscillation crystal	
X2	—			
XT1	Input	—	To connect subsystem clock oscillation crystal	
XT2	—			
ANI0-ANI7	Input	P10-P17	Analog voltage input for A/D converter	
ANO0, ANO1	Output	P130, P131	Analog voltage output for D/A converter	
AV <sub>REF0</sub>	—	—	To apply reference voltage for A/D converter	
AV <sub>REF1</sub>			To apply reference voltage for D/A converter	
AV <sub>DD</sub>			Positive power supply for A/D converter. Connected to V <sub>DD</sub> .	
AV <sub>SS</sub>			GND for A/D converter and D/A converter. Connected to V <sub>SS</sub> .	
V <sub>DD</sub>			Positive power supply	
V <sub>SS</sub>			GND	
TEST			V <sub>PP</sub>	Directly connect this pin to V <sub>SS</sub> (this pin is for IC test).
V <sub>PP</sub>			TEST	Sets flash memory programming mode. To apply a high voltage when program is written or verified.

**5.3 I/O Circuit Type of Respective Pins and Recommended Connections of Unused Pins**

Table 5-1 shows symbols indicating the I/O circuit types of the respective pins and the recommended connection of unused pins.

For the circuit diagram of each type of I/O circuit, refer to **Figure 5-1**.

**Table 5-1. I/O Circuit Type of Respective Pins and Recommended Connections of Unused Pins (1/2)**

Pin Name	I/O Circuit Type	I/O	Recommended Connections of Unused Pins			
P00/INTP0	8-A	I/O	Input : Individually connected to V <sub>SS</sub> via resistor Output: Open			
P01/INTP1						
P02/INTP2/NMI						
P03/INTP3-P06/INTP6						
P10/ANI0-P17/ANI7	9	Input	Connected to V <sub>SS</sub> or V <sub>DD</sub>			
P20/RxD1/SI1	10-A	I/O	Input : Individually connected to V <sub>SS</sub> via resistor Output: Open			
P21/TxD1/SO1						
P22/ASCK1/SCK1						
P23/PCL						
P24/BUZ						
P25/SI0						
P26/SO0						
P27/SCK0						
P30/TO0-P32/TO2				8-A		
P33/TI1, P34/TI2						
P35/TI00, P36/TI01						
P37/EXA						
P40/AD0-P47/AD7	5-A					
P50/A8-P57/A15						
P60/A16-P63/A19						
P64/RD						
P65/WR						
P66/WAIT						
P67/ASTB						
P70/RxD2/SI2				8-A		
P71/TxD2/SO2						
P72/ASCK2/SCK2						
P80/A0-P87/A7						
P90-P95	13-D					
P100/TI5/TO5	8-A					
P101/TI6/TO6						
P102/TI7/TO7						
P103/TI8/TO8						
P120/RTP0-P127/RTP7						
P130/ANO0, P131/ANO1	12-A					

Table 5-1. I/O Circuit Type of Respective Pins and Recommended Connections of Unused Pins (2/2)

Pin Name	I/O Circuit Type	I/O	Recommended Connections of Unused Pins
RESET	2	Input	—
XT1	16	—	Connected to V <sub>SS</sub>
XT2			Open
AV <sub>REF0</sub>	—	—	Connected to V <sub>SS</sub>
AV <sub>REF1</sub>			Connected to V <sub>DD</sub>
AV <sub>DD</sub>			Connected to V <sub>SS</sub>
AV <sub>SS</sub>			Connected to V <sub>SS</sub>
TEST/V <sub>PP</sub>			Directly connected to V <sub>SS</sub>

**Remark** Because the circuit type numbers are standardized among the 78K series products, they are not sequential in some models (i.e., some circuits are not provided).



Figure 5-1. Types of Pin I/O Circuits

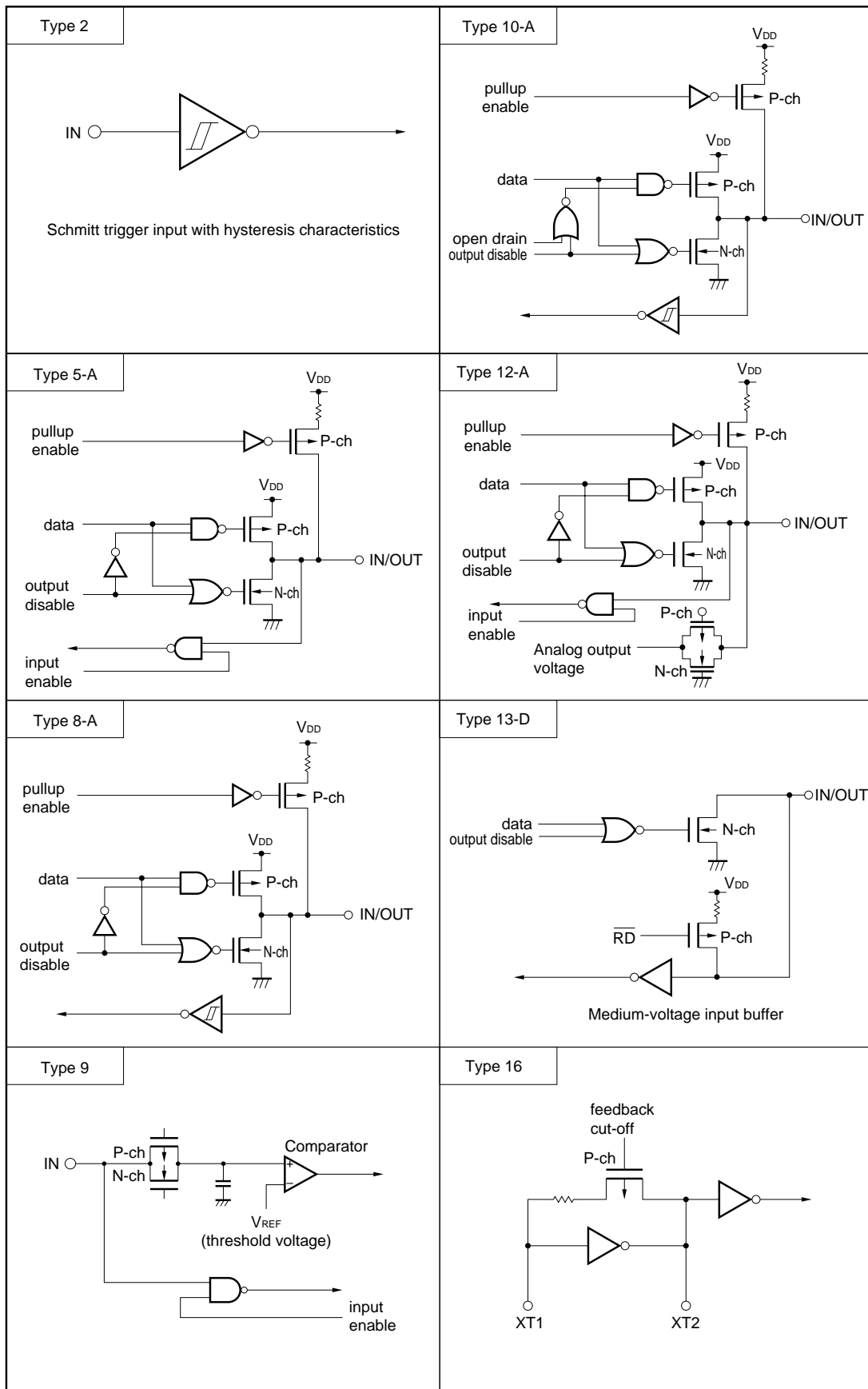

### 6. INTERNAL MEMORY SIZE SELECT REGISTER (IMS)

The IMS is a register that prevents by software a part of the internal memory from being used. By using this register, the memory of the μPD78F4218 can be mapped in the same manner as a mask ROM model with different internal memory (ROM and RAM) capacity.

This register is set by using an 8-bit memory manipulation instruction.  
Its value is set to FFH by RESET input.

**Figure 6-1. Format of Internal Memory Size Select Register (IMS)**

Address: 0FFFCH	At reset: FFH	W						
	7	6	5	4	3	2	1	0
IMS	1	1	ROM1	ROM0	1	1	RAM1	RAM0

ROM1	ROM0	Selects internal ROM capacity
0	0	64K bytes
0	1	128K bytes
1	0	192K bytes
1	1	256K bytes

RAM1	RAM0	Selects peripheral RAM capacity
0	0	3072 bytes
0	1	6656 bytes
1	0	7168 bytes
1	1	12288 bytes

**Caution** IMS is not provided on the mask ROM models (μPD784217 and 784218).

The value to be set to the IMS to map the memory of the μPD78F4218 in the same manner as the mask ROM model is shown in Table 6-1.

**Table 6-1. Set Value of Internal Memory Size Select Register (IMS)**

Mask ROM Model	Set Value of IMS
μPD784217	EFH
μPD784218	FFH

## 7. PROGRAMMING FLASH MEMORY

The flash memory can be written with the μPD78F4218 mounted on the target board (on-board). To do so, connect a dedicated flash writer (Flashpro II) to the host machine and target system.

**Remark** Flashpro II is a product of Naito Densetsu Machida Mfg. Co., Ltd.

### 7.1 Selecting Communication Mode

To write the flash memory, use Flashpro II and serial communication. Select a serial communication mode from those listed in Table 7-1 in the format shown in Figure 7-1. Each communication mode is selected by the number of V<sub>PP</sub> pulses shown in Table 7-1.

**Table 7-1. Communication Modes**

Communication Mode	Number of Channels	Pins Used	Number of V <sub>PP</sub> Pulses
3-wire serial I/O	3	SCK0/P27 SO0/P26 SI0/P25	0
		SCK1/ASCK1/P22 SO1/TxD1/P21 SI1/RxD1/P20	1
		SCK2/ASCK2/P72 SO2/TxD2/P71 SI2/RxD2/P70	2
UART	2	TxD1/SO1/P21 RxD1/SI1/P20	8
		TxD2/SO2/P71 RxD2/SI2/P70	9

**Caution** Be sure to select a communication mode with the number of V<sub>PP</sub> pulses shown in Table 7-1.

**Figure 7-1. Communication Mode Selecting Format**

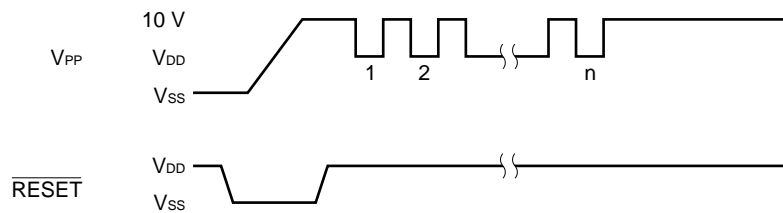

### 7.2 Flash Memory Programming Function

The flash memory is written by transferring or receiving commands and data in a selected communication mode. The major functions of flush memory programming are listed in Table 7-2.

**Table 7-2. Major Functions of Flash Memory Programming**

Function	Description
Batch erasure	Erases all contents of memory.
Block erasure	Erases contents of specified memory block with one memory block consisting of 16K bytes.
Batch blank check	Checks erased status of entire memory.
Block blank check	Checks erased status of specified block
Data write	Writes flash memory based on write start address and number of data to be written (in bytes).
Batch verify	Compares all contents of memory with input data.
Block verify	Compares contents of specified memory block with input data.

### 7.3 Connecting Flashpro II

The Flashpro II and μPD78F4218 are connected differently depending on the selected communication mode (3-wire serial I/O or UART). Figures 7-2 and 7-3 show the connections in the respective communication modes.

**Figure 7-2. Connection of Flashpro II in 3-Wire Serial I/O Mode (when using 3-wire serial I/O0)**

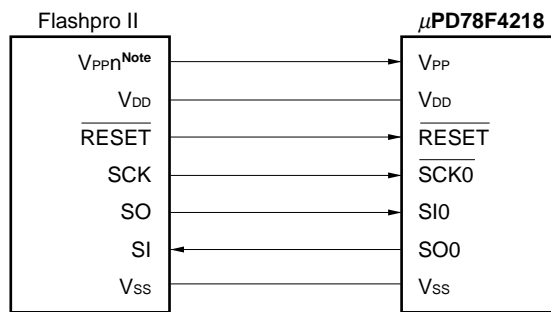

**Note** n = 1, 2

**Figure 7-3. Connection of Flashpro II in UART Mode (when using UART1)**

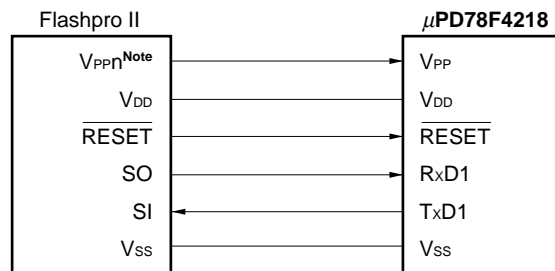

**Note** n = 1, 2

8. PACKAGE DRAWINGS

100 PIN PLASTIC QFP (FINE PITCH) (□14)

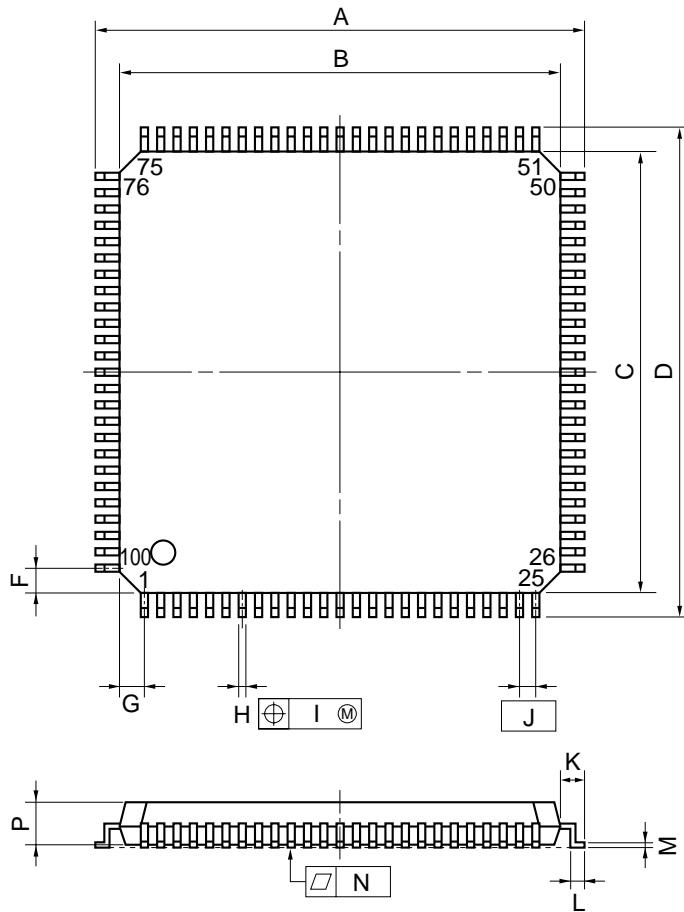

NOTE

Each lead centerline is located within 0.10 mm (0.004 inch) of its true position (T.P.) at maximum material condition.

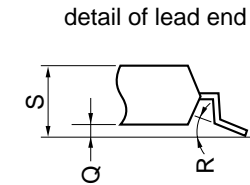

ITEM	MILLIMETERS	INCHES
A	16.0±0.2	0.630±0.008
B	14.0±0.2	0.551 <sup>+0.009</sup> <sub>-0.008</sub>
C	14.0±0.2	0.551 <sup>+0.009</sup> <sub>-0.008</sub>
D	16.0±0.2	0.630±0.008
F	1.0	0.039
G	1.0	0.039
H	0.22 <sup>+0.05</sup> <sub>-0.04</sub>	0.009±0.002
I	0.10	0.004
J	0.5 (T.P.)	0.020 (T.P.)
K	1.0±0.2	0.039 <sup>+0.009</sup> <sub>-0.008</sub>
L	0.5±0.2	0.020 <sup>+0.008</sup> <sub>-0.009</sub>
M	0.17 <sup>+0.03</sup> <sub>-0.07</sub>	0.007 <sup>+0.001</sup> <sub>-0.003</sub>
N	0.10	0.004
P	1.45	0.057
Q	0.125±0.075	0.005±0.003
R	5°±5°	5°±5°
S	1.7 MAX.	0.067 MAX.

P100GC-50-7EA-2

100 PIN PLASTIC QFP (14 × 20)

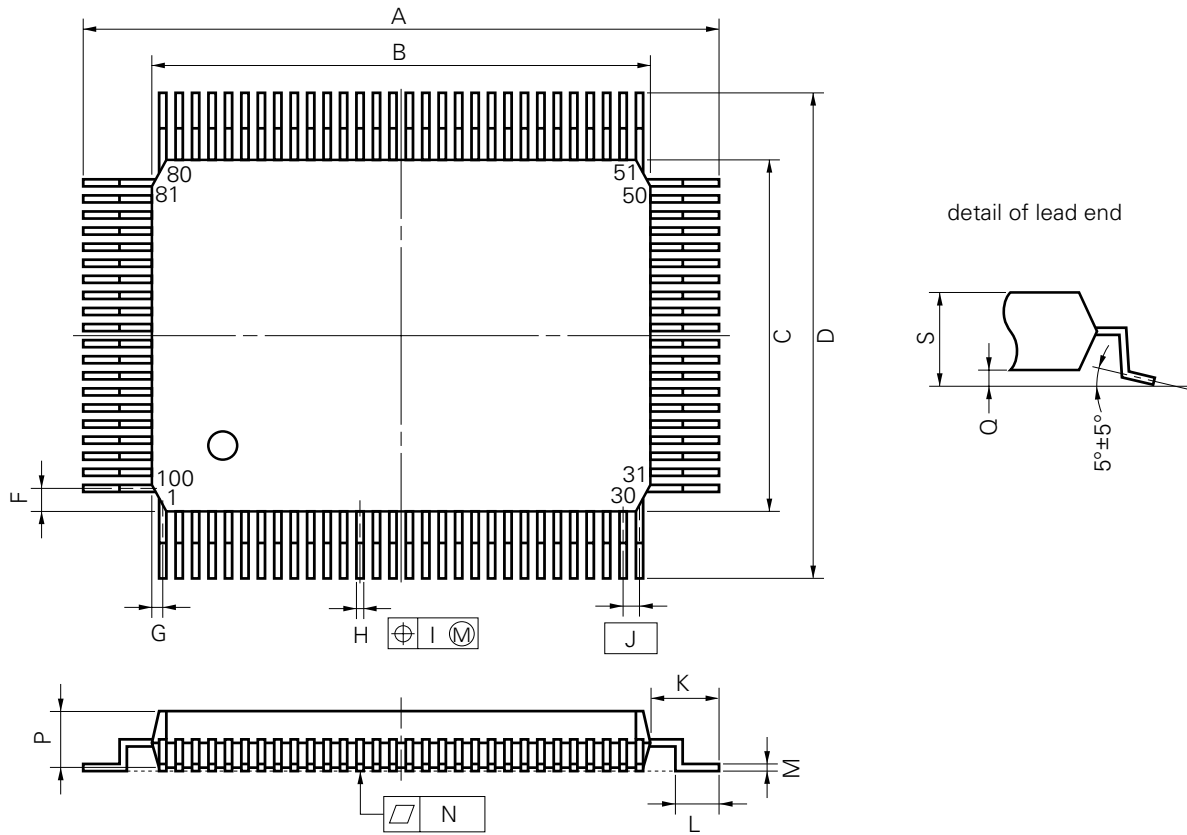

**NOTE**

Each lead centerline is located within 0.15 mm (0.006 inch) of its true position (T.P.) at maximum material condition.

P100GF-65-3BA1-2

ITEM	MILLIMETERS	INCHES
A	23.6±0.4	0.929±0.016
B	20.0±0.2	0.795 <sup>+0.009</sup> <sub>-0.008</sub>
C	14.0±0.2	0.551 <sup>+0.009</sup> <sub>-0.008</sub>
D	17.6±0.4	0.693±0.016
F	0.8	0.031
G	0.6	0.024
H	0.30±0.10	0.012 <sup>+0.004</sup> <sub>-0.005</sub>
I	0.15	0.006
J	0.65 (T.P.)	0.026 (T.P.)
K	1.8±0.2	0.071 <sup>+0.008</sup> <sub>-0.009</sub>
L	0.8±0.2	0.031 <sup>+0.009</sup> <sub>-0.008</sub>
M	0.15 <sup>+0.10</sup> <sub>-0.05</sub>	0.006 <sup>+0.004</sup> <sub>-0.003</sub>
N	0.10	0.004
P	2.7	0.106
Q	0.1±0.1	0.004±0.004
S	3.0 MAX.	0.119 MAX.

**APPENDIX A. DEVELOPMENT TOOLS**

The following development tools are available for supporting development of a system using the μPD78F4218.

**Language processor software**

RA78K4 <sup>Note 1</sup>	Assembler package common to 78K/IV series
CC78K4 <sup>Note 1</sup>	C compiler package common to 78K/IV series
CC78K4-L <sup>Note 1</sup>	C compiler library source file common to 78K/IV series

**Flash memory writing tool**

Flashpro II	Dedicated flash writer. Flashpro II is a product of Naito Densai Machida Mfg. Co., Ltd.
FA-100GC FA-100GF	Adapter for flash memory writing. Flash memory writing adapter is a product of Naito Densai Machida Mfg. Co., Ltd.

**Debugging tool**

IE-784000-R	In-circuit emulator common to 78K/IV series
IE-784000-R-BK	Break board common to 78K/IV series
IE-784218-R-EM1 IE-784000-R-EM	Emulation board for evaluation of μPD784218 subseries
IE-70000-98-IF-B	Interface adapter when PC-9800 series (except notebook type) is used as host machine
IE-70000-98N-IF	Interface adapter and cable when notebook type PC-9800 series is used as host machine
IE-70000-PC-IF-B	Interface adapter when IBM PC/AT™ is used as host machine
IE-78000-R-SV3	Interface adapter and cable when EWS is used as host machine
EP-78064GC-R	Emulation probe for 100-pin plastic QFP (fine pitch) (GC-7EA type) common to μPD784218 subseries
EP-78064GF-R	Emulation probe for 100-pin plastic QFP (GC-3BA type) common to μPD784218 subseries
TGC-100SDW	Adapter mounted on board of target system created for 100-pin plastic QFP (fine pitch) (GC-7EA type). TGC-100SDW is a product of Tokyo Eletech Corporation ((03) 5295-1661). Consult NEC when purchasing the product.
EV-9200GF-100	Socket mounted on board of target system created for 100-pin plastic QFP (GF-3BA type)
SM78K4 <sup>Note 2</sup>	System simulator common to 78K/IV series
ID78K4 <sup>Note 2</sup>	Integrated debugger for IE-784000-R
DF784218 <sup>Note 3</sup>	Device file for μPD784218 subseries

**Real-time OS**

RX78K/IV <sup>Note 3</sup>	Real-time OS for 78K/IV series
MX78K4 <sup>Note 4</sup>	OS for 78K/IV series

**Remark** RA78K4, CC78K4, SM78K4, and ID78K4 are used in combination with DF784218.

- Notes**
1.
    - PC-9800 series (MS-DOS™) base
    - IBM PC/AT and compatible machine (PC DOS™, Windows™, MS-DOS, IBM DOS™) base
    - HP9000 series 700™ (HP-UX™) base
    - SPARCstation™ (SunOS™) base
    - NEWS™ (NEWS-OS™) base
  2.
    - PC-9800 series (MS-DOS+Windows) base
    - IBM PC/AT and compatible machine (PC DOS, Windows, MS-DOS, IBM DOS) base
    - HP9000 series 700 (HP-UX) base
    - SPARCstation (SunOS) base
  3.
    - PC-9800 series (MS-DOS) base
    - IBM PC/AT and compatible machine (PC DOS, Windows, MS-DOS, IBM DOS) base
    - HP9000 series 700 (HP-UX) base
    - SPARCstation (SunOS) base
  4.
    - PC-9800 series (MS-DOS) base
    - IBM PC/AT and compatible machine (PC DOS, Windows, MS-DOS, IBM DOS) base



**APPENDIX B. RELATED DOCUMENTS**

**Documents related to device**

Document Name	Document No.	
	Japanese	English
μPD784217, 784218 Preliminary Product Information	U12303J	Planned
μPD78F4218 Preliminary Product Information	U11813J	This document
μPD784218, 784218Y Subseries User's Manual - Hardware	Planned	Planned
μPD784218 Subseries Special Function Register Table	Planned	–
78K/IV Series User's Manual - Instruction	U10905J	U10905E
78K/IV Series Instruction Table	U10594J	–
78K/IV Series Instruction Set	U10595J	–
78K/IV Series Application Note - Software Basics	U10095J	–

**Documents related to development tools (User's Manuals)**

Document Name		Document No.	
		Japanese	English
RA78K4 Assembler Package	Operation	U11334J	U11334E
	Language	U11162J	–
RA78K Series Structured Assembler Preprocessor		EEU-817	EEU-1402
CC78K4 Series	Operation	EEU-960	–
	Language	EEU-961	–
CC78K Series Library Source File		U12322J	–
IE-784000-R		EEU-5004	EEU-1534
IE-784218-R-EM1		U12155J	U12155E
EP-78064		EEU-934	EEU-1469
SM78K4 System Simulator - Windows base	Reference	U10093J	U10093E
SM78K Series System Simulator	External component user open interface specification	U10092J	U10092E
ID78K4 Integrated Debugger - Windows base	Reference	U10440J	U10440E

**Caution** The contents of the above related documents are subject to change without notice. Be sure to use the latest edition of a document for designing.

**Documents related to embedded software (User's Manual)**

Document Name		Document No.	
		Japanese	English
78K/IV Series Real-Time OS	Basics	U10603J	–
	Installation	U10604J	–
	Debugger	U10364J	–
78K/IV Series OS MX78K4	Basics	U11779J	–

**Other documents**

Document Name		Document No.	
		Japanese	English
IC Package Manual		C10943X	
Semiconductor Device Mounting Technology Manual		C10535J	C10535E
Quality Grades on NEC Semiconductor Devices		C11531J	C11531E
NEC Semiconductor Device Reliability/Quality Control System		C10983J	C10983E
Electrostatic Discharge (ESD) Test		MEM-539	–
Guide to Quality Assurance for Semiconductor Devices		C11893J	MEI-1202
Guide to Microcomputer-Related Products by Third Parties		U11416J	–

**Caution** The contents of the above related documents are subject to change without notice. Be sure to use the latest edition of a document for designing.

[MEMO]

[MEMO]

[MEMO]

## NOTES FOR CMOS DEVICES

### ① PRECAUTION AGAINST ESD FOR SEMICONDUCTORS

**Note:** Strong electric field, when exposed to a MOS device, can cause destruction of the gate oxide and ultimately degrade the device operation. Steps must be taken to stop generation of static electricity as much as possible, and quickly dissipate it once, when it has occurred. Environmental control must be adequate. When it is dry, humidifier should be used. It is recommended to avoid using insulators that easily build static electricity. Semiconductor devices must be stored and transported in an anti-static container, static shielding bag or conductive material. All test and measurement tools including work bench and floor should be grounded. The operator should be grounded using wrist strap. Semiconductor devices must not be touched with bare hands. Similar precautions need to be taken for PW boards with semiconductor devices on it.

### ② HANDLING OF UNUSED INPUT PINS FOR CMOS

**Note:** No connection for CMOS device inputs can be cause of malfunction. If no connection is provided to the input pins, it is possible that an internal input level may be generated due to noise, etc., hence causing malfunction. CMOS device behave differently than Bipolar or NMOS devices. Input levels of CMOS devices must be fixed high or low by using a pull-up or pull-down circuitry. Each unused pin should be connected to  $V_{DD}$  or GND with a resistor, if it is considered to have a possibility of being an output pin. All handling related to the unused pins must be judged device by device and related specifications governing the devices.

### ③ STATUS BEFORE INITIALIZATION OF MOS DEVICES

**Note:** Power-on does not necessarily define initial status of MOS device. Production process of MOS does not define the initial operation status of the device. Immediately after the power source is turned ON, the devices with reset function have not yet been initialized. Hence, power-on does not guarantee out-pin levels, I/O settings or contents of registers. Device is not initialized until the reset signal is received. Reset operation must be executed immediately after power-on for devices having reset function.

## Regional Information

Some information contained in this document may vary from country to country. Before using any NEC product in your application, please contact the NEC office in your country to obtain a list of authorized representatives and distributors. They will verify:

- Device availability
- Ordering information
- Product release schedule
- Availability of related technical literature
- Development environment specifications (for example, specifications for third-party tools and components, host computers, power plugs, AC supply voltages, and so forth)
- Network requirements

In addition, trademarks, registered trademarks, export restrictions, and other legal issues may also vary from country to country.

### **NEC Electronics Inc. (U.S.)**

Santa Clara, California  
Tel: 800-366-9782  
Fax: 800-729-9288

### **NEC Electronics (Germany) GmbH**

Duesseldorf, Germany  
Tel: 0211-65 03 02  
Fax: 0211-65 03 490

### **NEC Electronics (UK) Ltd.**

Milton Keynes, UK  
Tel: 01908-691-133  
Fax: 01908-670-290

### **NEC Electronics Italiana s.r.l.**

Milano, Italy  
Tel: 02-66 75 41  
Fax: 02-66 75 42 99

### **NEC Electronics (Germany) GmbH**

Benelux Office  
Eindhoven, The Netherlands  
Tel: 040-2445845  
Fax: 040-2444580

### **NEC Electronics (France) S.A.**

Velizy-Villacoublay, France  
Tel: 01-30-67 58 00  
Fax: 01-30-67 58 99

### **NEC Electronics (France) S.A.**

Spain Office  
Madrid, Spain  
Tel: 01-504-2787  
Fax: 01-504-2860

### **NEC Electronics (Germany) GmbH**

Scandinavia Office  
Taebly, Sweden  
Tel: 08-63 80 820  
Fax: 08-63 80 388

### **NEC Electronics Hong Kong Ltd.**

Hong Kong  
Tel: 2886-9318  
Fax: 2886-9022/9044

### **NEC Electronics Hong Kong Ltd.**

Seoul Branch  
Seoul, Korea  
Tel: 02-528-0303  
Fax: 02-528-4411

### **NEC Electronics Singapore Pte. Ltd.**

United Square, Singapore 1130  
Tel: 253-8311  
Fax: 250-3583

### **NEC Electronics Taiwan Ltd.**

Taipei, Taiwan  
Tel: 02-719-2377  
Fax: 02-719-5951

### **NEC do Brasil S.A.**

Sao Paulo-SP, Brasil  
Tel: 011-889-1680  
Fax: 011-889-1689

**IEBus is a trademark of NEC Corp.**

**MS-DOS and Windows are registered trademarks and trademarks of Microsoft Corp. in the U.S. and other countries.**

**IBM DOS, PC/AT, and PC DOS are trademarks of IBM Corp.**

**HP9000 series 700 and HP-UX are trademarks of Hewlett-Packard Co.**

**SPARCstation is a trademark of SPARC International, Inc.**

**SunOS is a trademark of Sun Microsystems, Inc.**

**NEWS and NEWS-OS are trademarks of Sony Corp.**

The related documents indicated in this publication may include preliminary versions. However, preliminary versions are not marked as such.

No part of this document may be copied or reproduced in any form or by any means without the prior written consent of NEC Corporation. NEC Corporation assumes no responsibility for any errors which may appear in this document.

NEC Corporation does not assume any liability for infringement of patents, copyrights or other intellectual property rights of third parties by or arising from use of a device described herein or any other liability arising from use of such device. No license, either express, implied or otherwise, is granted under any patents, copyrights or other intellectual property rights of NEC Corporation or others.

While NEC Corporation has been making continuous effort to enhance the reliability of its semiconductor devices, the possibility of defects cannot be eliminated entirely. To minimize risks of damage or injury to persons or property arising from a defect in an NEC semiconductor device, customers must incorporate sufficient safety measures in its design, such as redundancy, fire-containment, and anti-failure features.

NEC devices are classified into the following three quality grades:

"Standard", "Special", and "Specific". The Specific quality grade applies only to devices developed based on a customer designated "quality assurance program" for a specific application. The recommended applications of a device depend on its quality grade, as indicated below. Customers must check the quality grade of each device before using it in a particular application.

Standard: Computers, office equipment, communications equipment, test and measurement equipment, audio and visual equipment, home electronic appliances, machine tools, personal electronic equipment and industrial robots

Special: Transportation equipment (automobiles, trains, ships, etc.), traffic control systems, anti-disaster systems, anti-crime systems, safety equipment and medical equipment (not specifically designed for life support)

Specific: Aircrafts, aerospace equipment, submersible repeaters, nuclear reactor control systems, life support systems or medical equipment for life support, etc.

The quality grade of NEC devices is "Standard" unless otherwise specified in NEC's Data Sheets or Data Books. If customers intend to use NEC devices for applications other than those specified for Standard quality grade, they should contact an NEC sales representative in advance.

Anti-radioactive design is not implemented in this product.