

8-BIT SINGLE-CHIP MICROCONTROLLER

The μPD789046 is a μPD789046 Subseries (small-scale, general-purpose applications) product of the 78K/0S Series.

A flash memory version (μPD78F9046) that can operate within the same power supply voltage range as the mask ROM version, and various development tools are being developed.

Detailed function descriptions are provided in the following user's manuals. Be sure to read them before designing.

μPD789046 Subseries User's Manual: U13600E

78K/0S Series Instructions User's Manual: U11047E

FEATURES

- Internal ROM: 16 Kbytes
- Internal high-speed RAM: 512 bytes
- Minimum instruction execution time can be changed from high-speed (0.4 μs: @ 5.0-MHz operation with main system clock) to ultra-low-speed (122 μs: @ 32.768-kHz operation with subsystem clock)
- I/O ports: 34
- Serial interface: 1 channel
Switchable between 3-wire serial I/O and UART modes
- Timer: 4 channels
 - 16-bit timer counter: 1 channel
 - 8-bit timer/event counter: 1 channel
 - Watch timer: 1 channel
 - Watchdog timer: 1 channel
- Vectored interrupt source: 12
- Power supply voltage: V_{DD} = 1.8 to 5.5 V
- Operating ambient temperature: T_A = -40 to +85°C

APPLICATIONS

Cordless phones, etc.

ORDERING INFORMATION

Part Number	Package
μPD789046GB-xxx-8ES	44-pin plastic LQFP (10 × 10 mm)

Remark xxx indicates ROM code suffix.

The information in this document is subject to change without notice. Before using this document, please confirm that this is the latest version.

Not all devices/types available in every country. Please check with local NEC representative for availability and additional information.

★ 78K/0S SERIES LINEUP

The products in the 78K/0S Series are listed below. The names enclosed in boxes are subseries names.

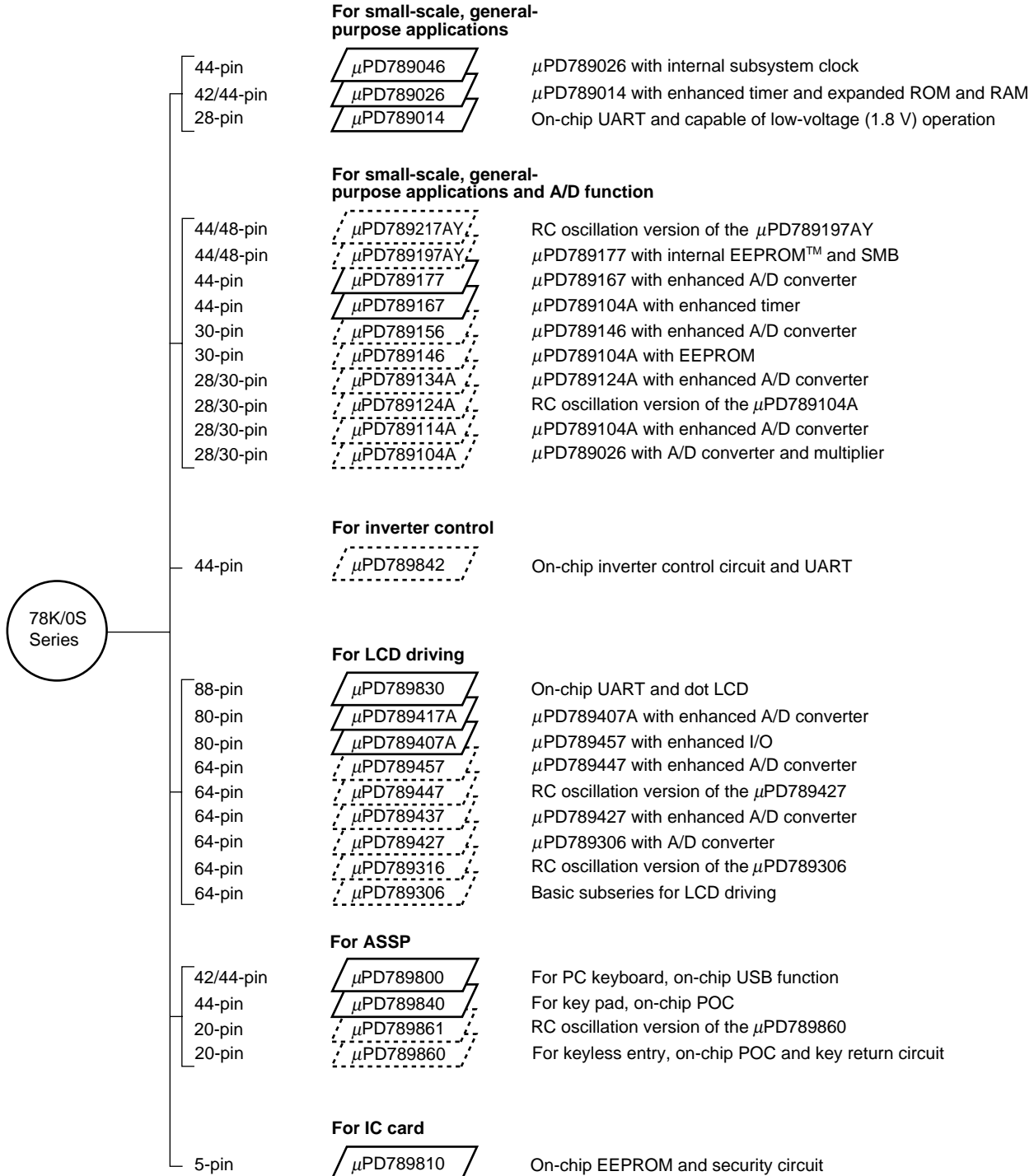
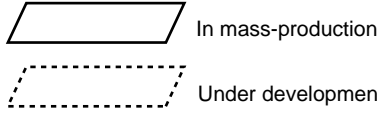

The major functional differences among the subseries are listed below.

Subseries Name	Function	ROM Capacity	Timer				8-bit A/D	10-bit A/D	Serial Interface	I/O	V _{DD} Min. Value	Remarks	
			8-bit	16-bit	Watch	WDT							
Small-scale, general-purpose applications	μPD789046	16 K	1 ch	1 ch	1 ch	1 ch	–	–	1 ch (UART: 1 ch)	34	1.8 V	–	
	μPD789026	4 K to 16 K			–								
	μPD789014	2 K to 4 K	2 ch	–						22			
Small-scale, general-purpose applications and A/D function	μPD789217AY	16 K to 24 K	3 ch	1 ch	1 ch	1 ch	–	8 ch	2 ch [UART: 1 ch] [SMB: 1 ch]	31	1.8 V	RC oscillation version, on-chip EEPROM	
	μPD789197AY											On-chip EEPROM	
	μPD789177											–	
	μPD789167				8 ch	–		1 ch (UART: 1 ch)					
	μPD789156	8 K to 16 K	1 ch		–		–	4 ch		20		On-chip EEPROM	
	μPD789146					4 ch	–						
	μPD789134A	2 K to 8 K					–	4 ch				RC oscillation version	
	μPD789124A						4 ch	–					
	μPD789114A						–	4 ch					–
μPD789104A						4 ch	–						
Inverter control	μPD789842	8 K to 16 K	3 ch	Note	1 ch	1 ch	8 ch	–	1 ch (UART: 1 ch)	30	4.0 V	–	
LCD driving	μPD789830	24 K	1 ch	1 ch	1 ch	1 ch	–	–	1 ch (UART: 1 ch)	30	2.7 V	–	
	μPD789417A	12 K to 24 K	3 ch					7 ch			43		1.8 V
	μPD789407A						7 ch	–			25		
	μPD789457	16 K to 24 K	2 ch				–	4 ch	2 ch (UART: 1 ch)			RC oscillation version	
	μPD789447					4 ch	–						
	μPD789437					–	4 ch						–
	μPD789427					4 ch	–						
	μPD789316	8 K to 16 K					–			23		RC oscillation version	
μPD789306												–	
ASSP	μPD789800	8 K	2 ch	1 ch	–	1 ch	–	–	2 ch (USB: 1 ch)	31	4.0 V	–	
	μPD789840						4 ch	–	1 ch	29	2.8 V		
	μPD789861	4 K		–			–	–	–	14	1.8 V	RC oscillation version	
	μPD789860										–		
IC card	μPD789810	6 K	–	–	–	1 ch	–	–	–	1	2.7 V	On-chip EEPROM	

Note 10-bit timer: 1 channel

OVERVIEW OF FUNCTIONS

Item		Function
Internal memory	ROM	16 Kbytes
	High-speed RAM	512 bytes
Minimum instruction execution time		<ul style="list-style-type: none"> • 0.4/1.6 μs (@ 5.0-MHz operation with main system clock) • 122 μs (@ 32.768-kHz operation with subsystem clock)
General-purpose registers		8 bits × 8 registers
Instruction set		<ul style="list-style-type: none"> • 16-bit operation • Bit manipulation (set, reset, and test), etc.
I/O ports		CMOS input/output: 34
Serial interface		Switchable between 3-wire serial I/O and UART modes: 1 channel
Timers		<ul style="list-style-type: none"> • 16-bit timer counter: 1 channel • 8-bit timer/event counter: 1 channel • Watch timer: 1 channel • Watchdog timer: 1 channel
Timer output		2
Vectored interrupt sources	Maskable	Internal: 7, external: 4
	Non-maskable	Internal: 1
Power supply voltage		V _{DD} = 1.8 to 5.5 V
Operating ambient temperature		T _A = -40 to +85°C
Package		44-pin plastic LQFP (10 × 10 mm)

CONTENTS

1. PIN CONFIGURATION (Top View).....	6
2. BLOCK DIAGRAM.....	7
3. PIN FUNCTIONS.....	8
3.1 Port Pins.....	8
3.2 Non-Port Pins.....	9
3.3 Pin I/O Circuits and Recommended Connection of Unused Pins.....	10
4. MEMORY SPACE	12
5. PERIPHERAL HARDWARE FUNCTIONS	13
5.1 Ports	13
5.2 Clock Generator.....	13
5.3 Timers.....	14
5.4 Serial Interface.....	16
6. INTERRUPT FUNCTIONS	17
7. STANDBY FUNCTIONS	19
8. RESET FUNCTIONS.....	19
9. INSTRUCTION SET OVERVIEW.....	20
9.1 Legend.....	20
9.2 Operations.....	22
10. ELECTRICAL SPECIFICATIONS.....	27
★ 11. CHARACTERISTICS CURVES	38
12. PACKAGE DRAWING	40
★ 13. RECOMMENDED SOLDERING CONDITIONS.....	41
APPENDIX A. DEVELOPMENT TOOLS	42
APPENDIX B. RELATED DOCUMENTS.....	44

1. PIN CONFIGURATION (Top View)

- 44-pin plastic LQFP (10 × 10 mm)
μPD789046GB-xxx-8ES

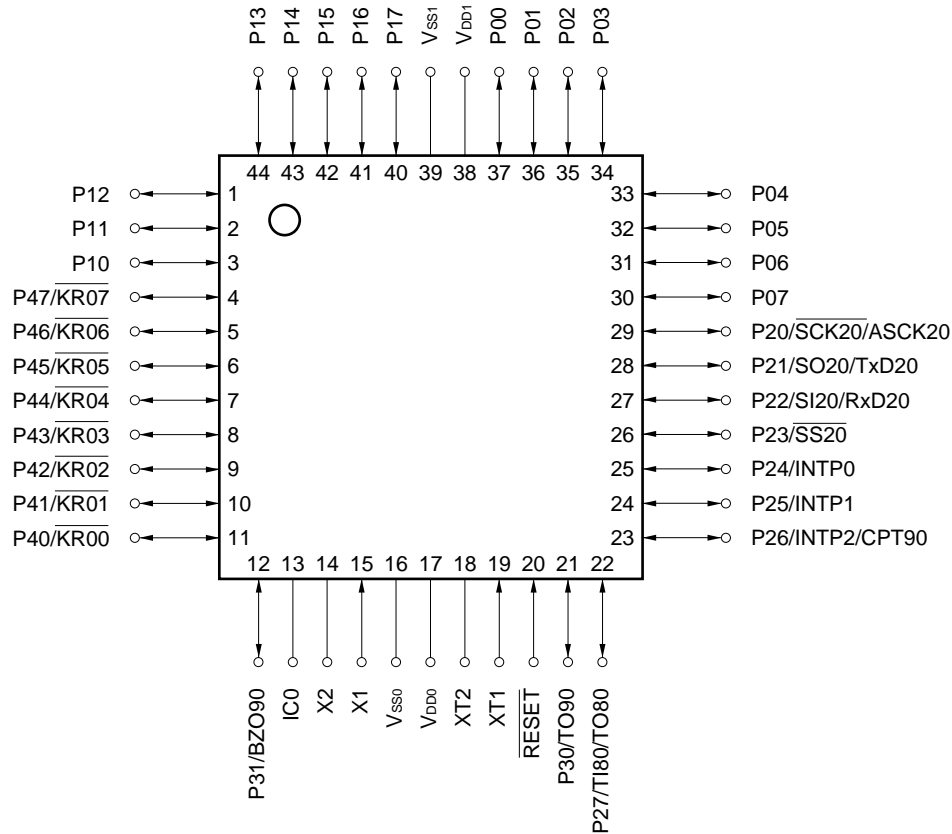

Caution Connect the IC0 (Internally Connected) pin directly to VSS0 or VSS1 pin.

ASCK20:	Asynchronous Serial Input	RxD20:	Receive Data
BZO90:	Buzzer Output	SCK20:	Serial Clock
CPT90:	Capture Trigger Input	SI20:	Serial Input
IC0:	Internally Connected	SO20:	Serial Output
INTP0 to INTP2:	Interrupt from Peripherals	SS20:	Chip Select Input
KR00 to KR07:	Key Return	TI80:	Timer Input
P00 to P07:	Port 0	TO80, TO90:	Timer Output
P10 to P17:	Port 1	TxD20:	Transmit Data
P20 to P27:	Port 2	VDD0, VDD1:	Power Supply
P30, P31:	Port 3	VSS0, VSS1:	Ground
P40 to P47:	Port 4	X1, X2:	Crystal (Main System Clock)
RESET:	Reset	XT1, XT2:	Crystal (Subsystem Clock)

2. BLOCK DIAGRAM

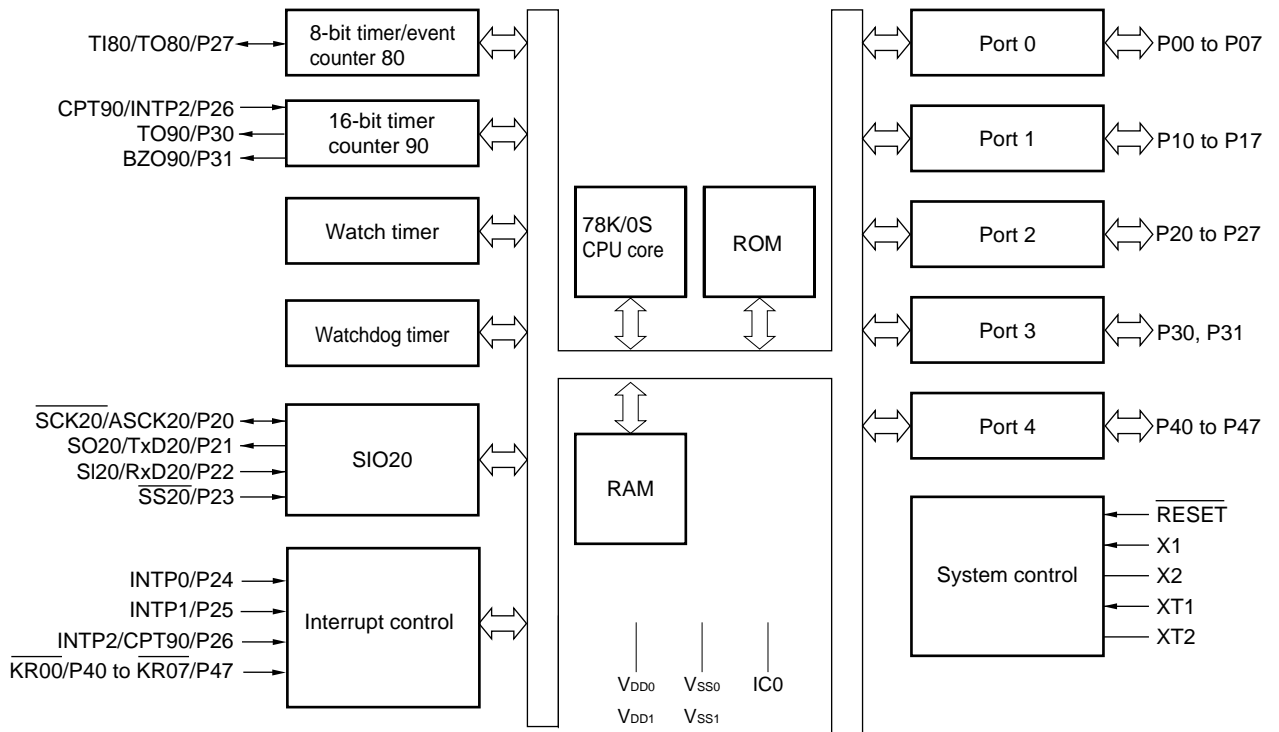

3. PIN FUNCTIONS

3.1 Port Pins

Pin Name	I/O	Function	After Reset	Alternate Function
P00 to P07	I/O	Port 0 8-bit input/output port Input/output can be specified in 1-bit units. When used as an input port, an on-chip pull-up resistor can be specified by means of software.	Input	–
P10 to P17	I/O	Port 1 8-bit input/output port Input/output can be specified in 1-bit units. When used as an input port, an on-chip pull-up resistor can be specified by means of software.	Input	–
P20	I/O	Port 2 8-bit input/output port Input/output can be specified in 1-bit units. An on-chip pull-up resistor can be specified by means of software.	Input	SCK20/ASCK20
P21				SO20/TxD20
P22				SI20/RxD20
P23				SS20
P24				INTP0
P25				INTP1
P26				INTP2/CPT90
P27				TI80/TO80
P30	I/O	Port 3 2-bit input/output port Input/output can be specified in 1-bit units. When used as an input port, an on-chip pull-up resistor can be specified by means of software.	Input	TO90
P31				BZO90
P40 to P47	I/O	Port 4 8-bit input/output port Input/output can be specified in 1-bit units. When used as an input port, an on-chip pull-up resistor can be specified by means of software.	Input	KR00 to KR07

3.2 Non-Port Pins

Pin Name	I/O	Function	After Reset	Alternate Function
INTP0	Input	External interrupt input for which the valid edge (rising edge, falling edge, or both rising and falling edges) can be specified	Input	P24
INTP1				P25
INTP2				P26/CPT90
$\overline{KR00}$ to $\overline{KR07}$	Input	Detection of key return signal	Input	P40 to P47
SI20	Input	Serial interface serial data input	Input	P22/RxD20
SO20	Output	Serial interface serial data output	Input	P21/TxD20
SCK20	I/O	Serial interface serial clock input/output	Input	P20/ASCK20
$\overline{SS20}$	Input	Serial interface chip select input	Input	P23
ASCK20	Input	Asynchronous serial interface serial clock input	Input	P20/ $\overline{SCK20}$
RxD20	Input	Asynchronous serial interface serial data input	Input	P22/SI20
TxD20	Output	Asynchronous serial interface serial data output	Input	P21/SO20
TI80	Input	External count clock input to 8-bit timer (TM80)	Input	P27/TO80
TO80	Output	8-bit timer (TM80) output	Input	P27/TI80
TO90	Output	16-bit timer (TM90) output	Input	P30
BZO90	Output	16-bit timer (TM90) buzzer output	Input	P31
CPT90	Input	Capture edge input	Input	P26/INTP2
X1	Input	Connecting crystal resonator for main system clock oscillation	–	–
X2	–		–	–
XT1	Input	Connecting crystal resonator for subsystem clock oscillation	–	–
XT2	–		–	–
V _{DD0}	–	Positive power supply for ports	–	–
V _{DD1}	–	Positive power supply except ports	–	–
V _{SS0}	–	Ground potential for ports	–	–
V _{SS1}	–	Ground potential except ports	–	–
\overline{RESET}	Input	System reset input	Input	–
IC0	–	Internally connected. Connect directly to V _{SS0} or V _{SS1} .	–	–

3.3 Pin I/O Circuits and Recommended Connection of Unused Pins

The input/output circuit type of each pin and recommended connection of unused pins are shown in Table 3-1.
 For the input/output circuit configuration of each type, refer to Figure 3-1.

Table 3-1. Types of Pin Input/Output Circuits and Recommended Connection of Unused Pins

Pin Name	I/O Circuit Type	I/O	Recommended Connection of Unused Pins
P00 to P07	5-H	I/O	Input: Independently connect to V _{DD0} , V _{DD1} , V _{SS0} , or V _{SS1} via a resistor. Output: Leave open.
P10 to P17			
P20/ $\overline{\text{SCK20}}$ / $\overline{\text{ASCK20}}$	8-C		
P21/ $\overline{\text{SO20}}$ / $\overline{\text{TxD20}}$			
P22/ $\overline{\text{SI20}}$ / $\overline{\text{RxD20}}$			
P23/ $\overline{\text{SS20}}$			
P24/ $\overline{\text{INTP0}}$			
P25/ $\overline{\text{INTP1}}$			
P26/ $\overline{\text{INTP2}}$ / $\overline{\text{CPT90}}$			
P27/ $\overline{\text{TI80}}$ / $\overline{\text{TO80}}$			
P30/ $\overline{\text{TO90}}$	5-H		
P31/ $\overline{\text{BZO90}}$			
P40/ $\overline{\text{KR00}}$ to P47/ $\overline{\text{KR07}}$	8-C		
XT1	–	Input	Connect to V _{SS0} or V _{SS1} .
XT2	–	–	Leave open.
$\overline{\text{RESET}}$	2	Input	–
IC	–	–	Connect directly to V _{SS0} or V _{SS1} .

Figure 3-1. Pin Input/Output Circuits

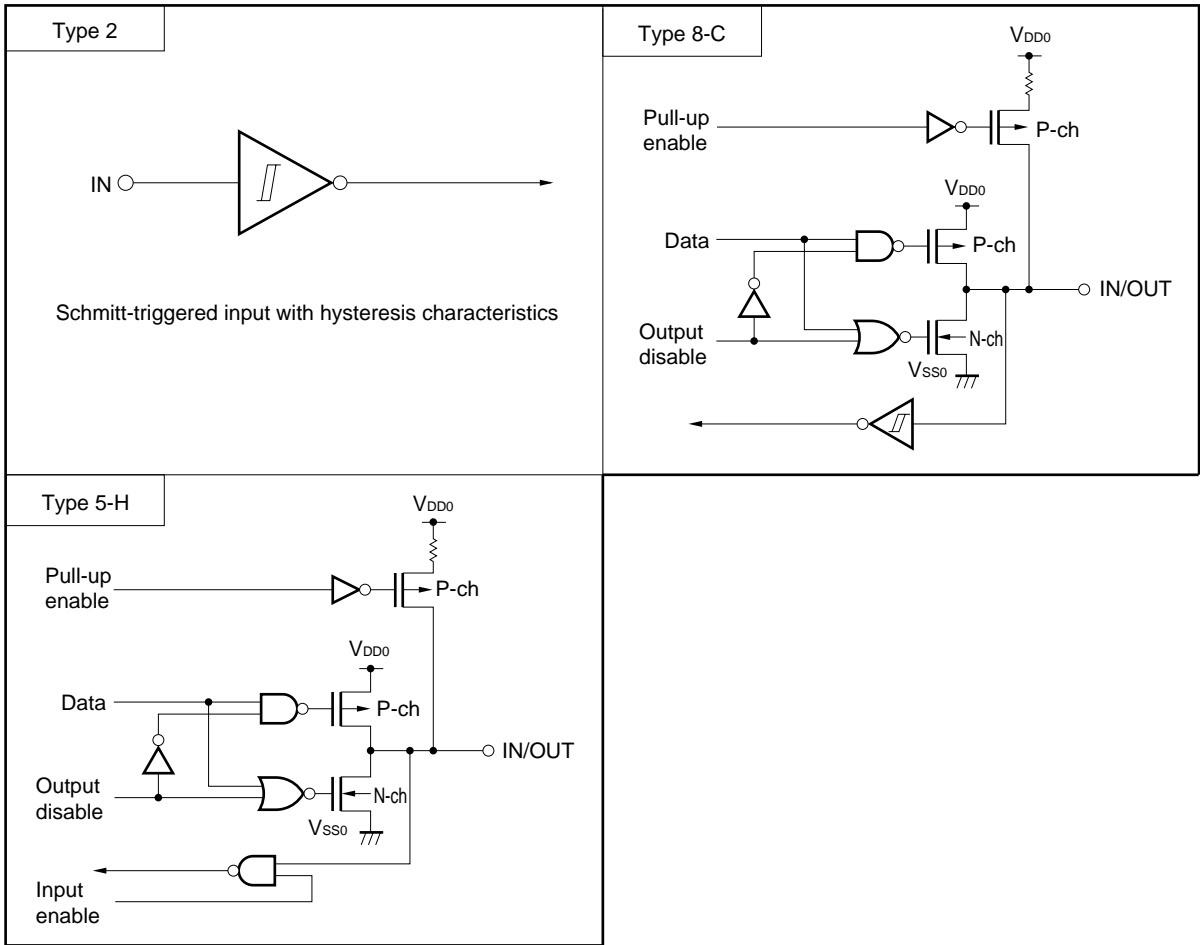

4. MEMORY SPACE

The μPD789046 can access 64 Kbytes of memory space. Figure 4-1 shows the memory map.

Figure 4-1. Memory Map

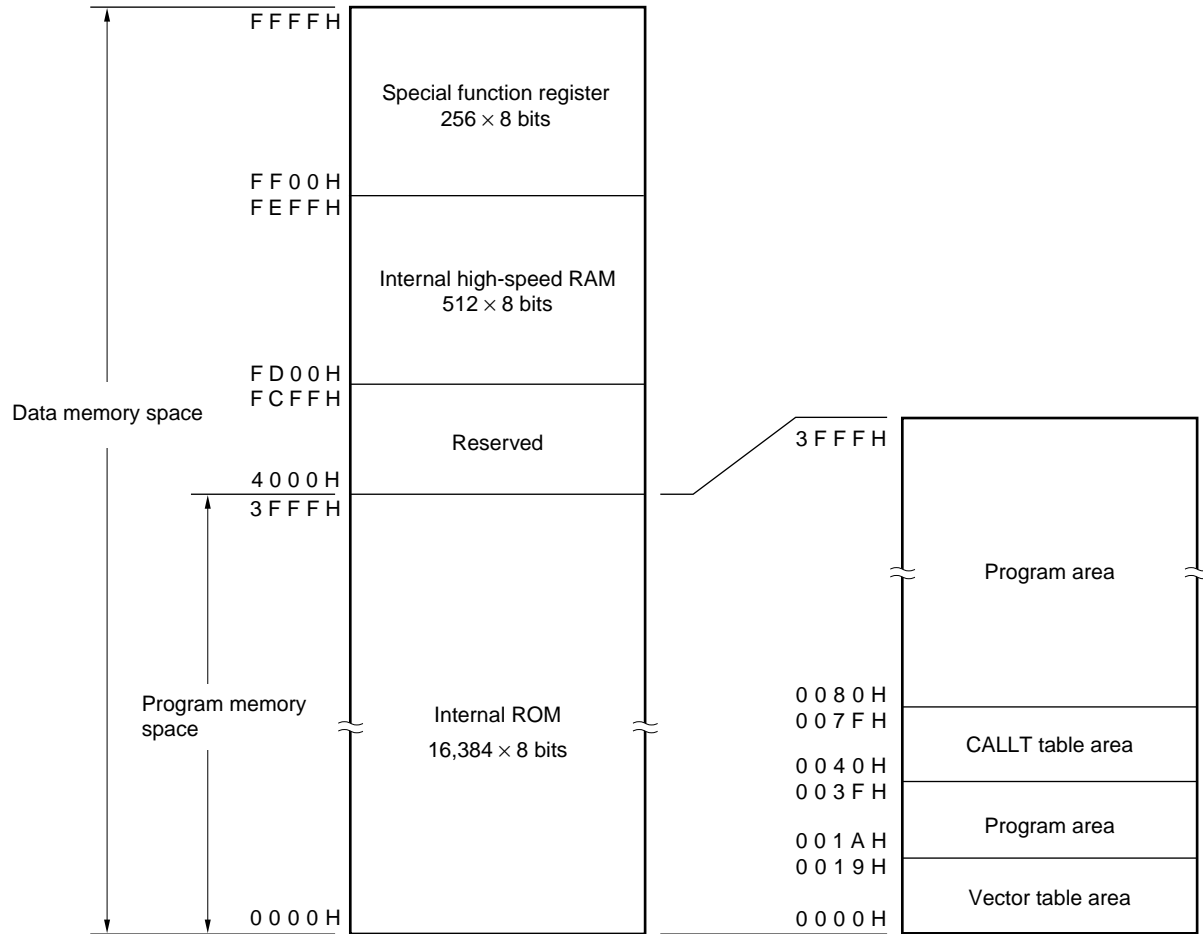

5. PERIPHERAL HARDWARE FUNCTIONS

5.1 Ports

The μPD789046 is provided with the following I/O ports and various controls are available.

Table 5-1. Port Functions

Port Name	Pin Name	Function
Port 0	P00 to P07	Input/output port. Input/output can be specified in 1-bit units. When used as an input port, an on-chip pull-up resistor can be specified by means of software.
Port 1	P10 to P17	Input/output port. Input/output can be specified in 1-bit units. When used as an input port, an on-chip pull-up resistor can be specified by means of software.
Port 2	P20 to P27	Input/output port. Input/output can be specified in 1-bit units. An on-chip pull-up resistor can be specified by means of software.
Port 3	P30, P31	Input/output port. Input/output can be specified in 1-bit units. When used as an input port, an on-chip pull-up resistor can be specified by means of software.
Port 4	P40 to P47	Input/output port. Input/output can be specified in 1-bit units. When used as an input port, an on-chip pull-up resistor can be specified by means of software.

5.2 Clock Generator

A system clock generator is incorporated.

The minimum instruction execution time can be changed.

- 0.4 μs/1.6 μs (@ 5.0-MHz operation with main system clock)
- 122 μs (@ 32.768-kHz operation with subsystem clock)

Figure 5-1. Clock Generator Block Diagram

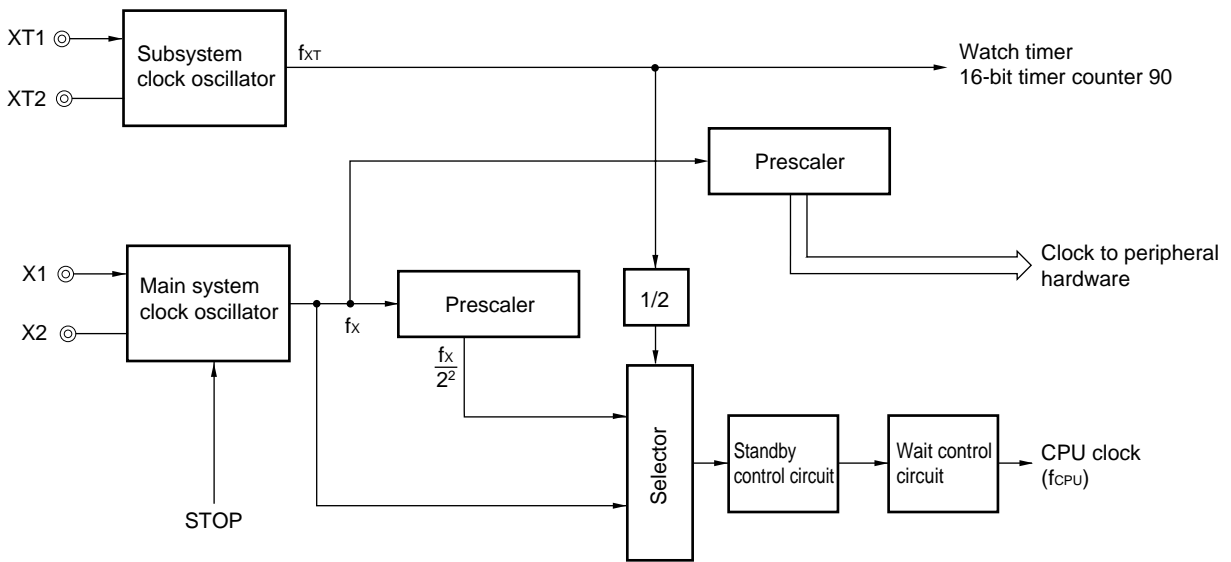

5.3 Timers

Four timer channels are incorporated.

- 16-bit timer counter 90 (TM90): 1 channel
- 8-bit timer/event counter 80 (TM80): 1 channel
- Watch timer (WT): 1 channel
- Watchdog timer (WDT): 1 channel

Table 5-2. Operations of Timers

		TM90	TM80	WT	WDT
Operation mode	Interval timer	–	1 channel	1 channel	1 channel
	External event counter	–	1 channel	–	–
Function	Timer output	1 output	1 output	–	–
	Square wave output	–	1 output	–	–
	PWM output	–	1 output	–	–
	Buzzer output	1 output	–	–	–
	Capture	1 input	–	–	–
	Interrupt request	1	1	1	1

Figure 5-2. Block Diagram of 16-Bit Timer Counter 90

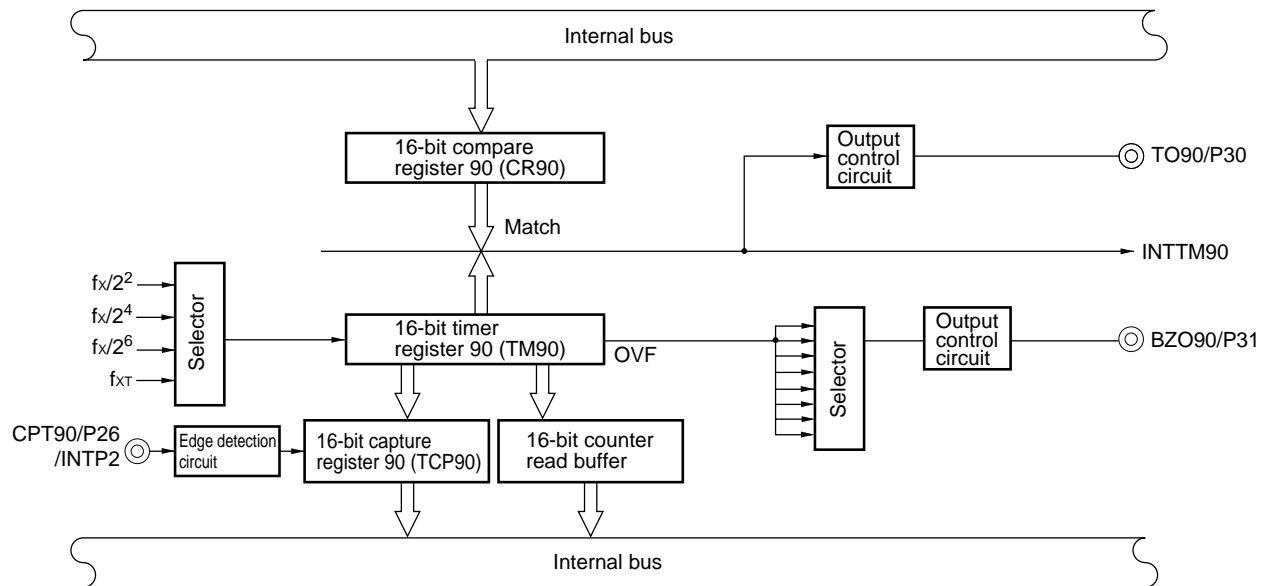

Figure 5-3. Block Diagram of 8-Bit Timer/Event Counter 80

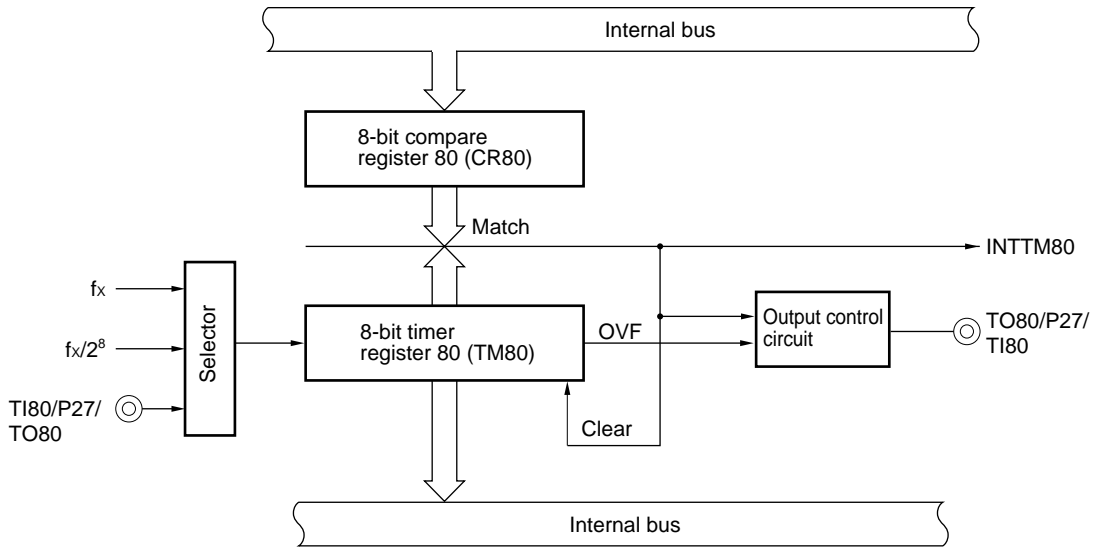
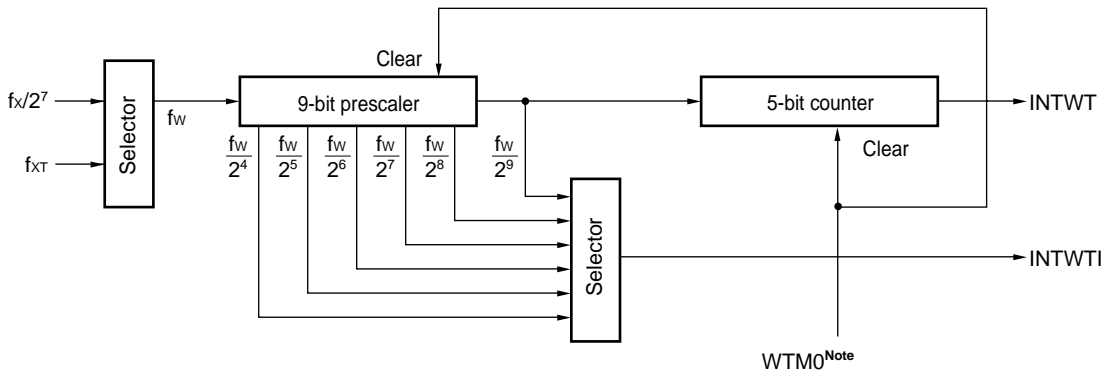
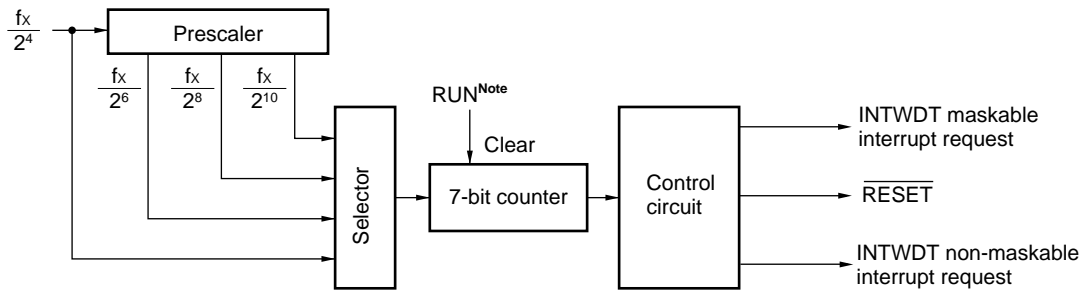

Figure 5-4. Watch Timer Block Diagram



Note Bit 0 of watch timer mode control register (WTM)

Figure 5-5. Watchdog Timer Block Diagram



Note Bit 7 of watchdog timer mode register (WDTM)

5.4 Serial Interface

One serial interface channel is incorporated.

Serial interface 20 has the following three types of modes.

- Operation stop mode: Can reduce power consumption
- 3-wire serial I/O mode: Switchable between MSB-first and LSB-first transmission
- Asynchronous serial interface (UART) mode: On-chip dedicated baud rate generator

Figure 5-6. Serial Interface Block Diagram

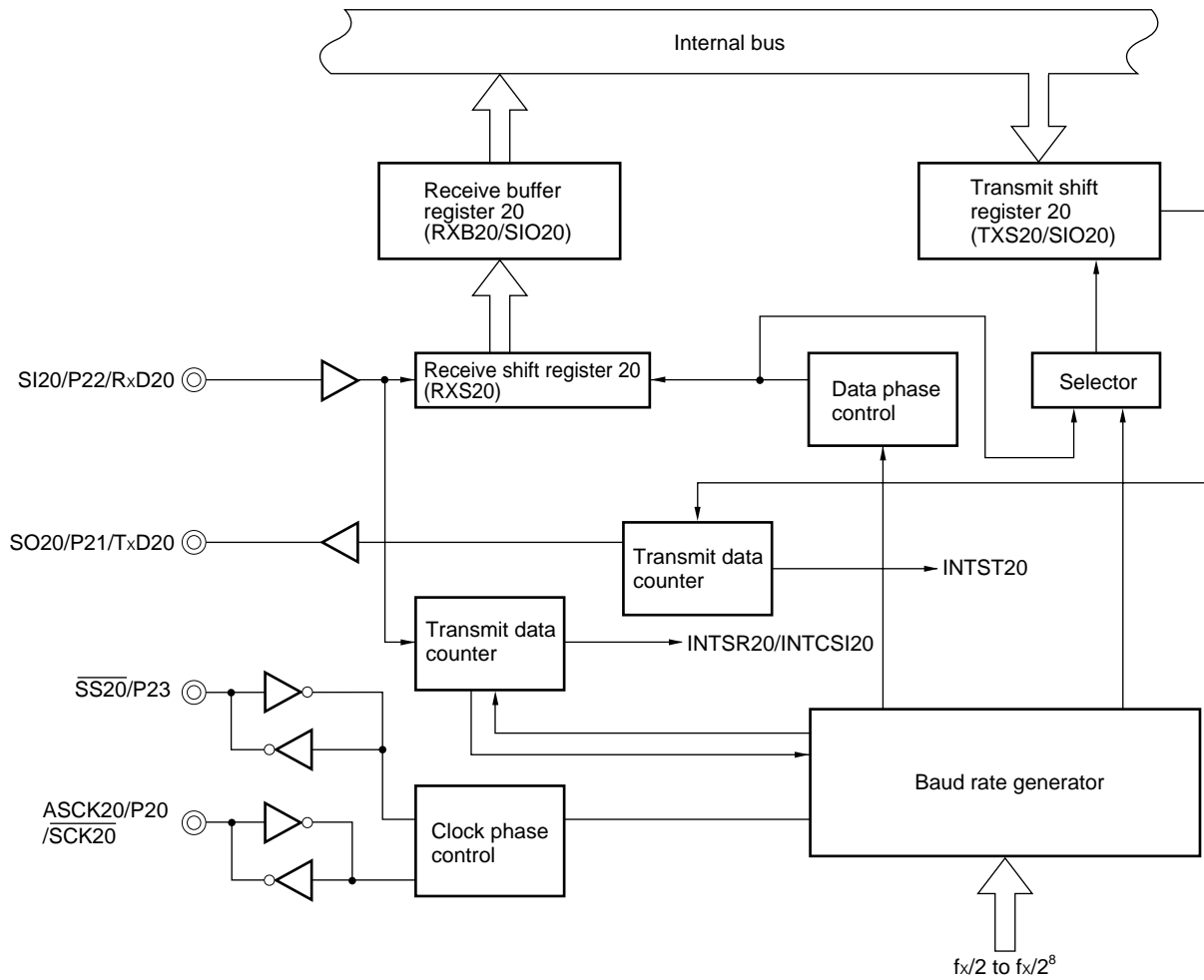

6. INTERRUPT FUNCTIONS

A total of 12 interrupt sources are provided, divided into the following two types.

- Non-maskable: 1
- Maskable: 11

Table 6-1. Interrupt Sources

Interrupt Type	Priority ^{Note 1}	Interrupt Source		Internal/External	Vector Table Address	Basic Configuration Type ^{Note 2}		
		Name	Trigger					
Non-maskable	–	INTWDT	Watchdog timer overflow (with watchdog timer mode 1 selected)	Internal	0004H	(A)		
Maskable	0	INTWDT	Watchdog timer overflow (with interval timer mode selected)					(B)
	1	INTP0	Pin input edge detection	External	0006H	(C)		
	2	INTP1			0008H			
	3	INTP2			000AH			
	4	INTSR20	End of serial interface 20 UART reception	Internal	000CH	(B)		
		INTCSI20	End of serial interface 20 3-wire SIO transfer reception					
	5	INTST20	End of serial interface 20 UART transmission				000EH	
	6	INTWT	Watch timer interrupt				0010H	
	7	INTWTI	Interval timer interrupt				0012H	
	8	INTTM80	Generation of matching signal of 8-bit timer/event counter 80				0014H	
	9	INTTM90	Generation of matching signal of 16-bit timer counter 90				0016H	
10	INTKR00	Detection of key return signal	External				0018H	(C)

- Notes**
1. Priority is the priority order when several maskable interrupts are generated at the same time. 0 is the highest order and 10 is the lowest order.
 2. Basic configuration types (A) to (C) correspond to (A) to (C) in Figure 6-1.

Figure 6-1. Basic Configuration of Interrupt Functions

(A) Internal non-maskable interrupt

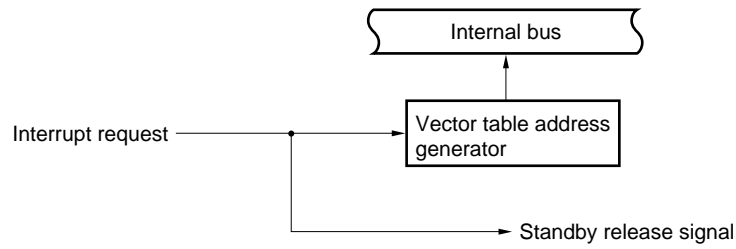

(B) Internal maskable interrupt

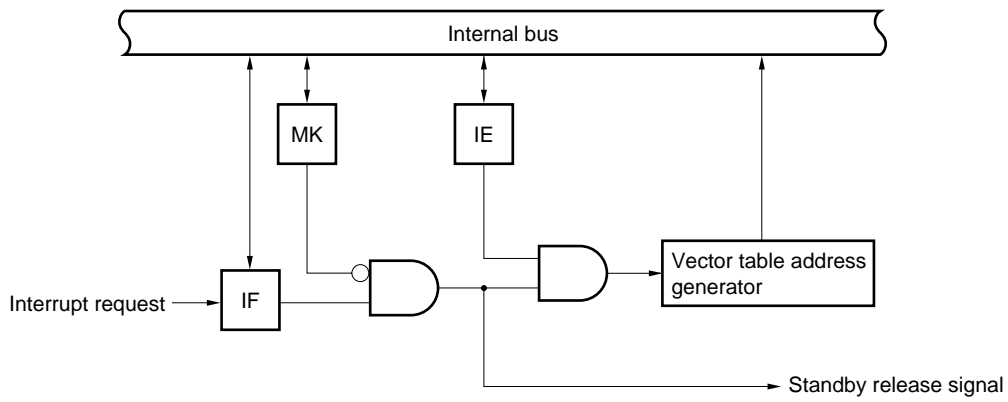

(C) External maskable interrupt

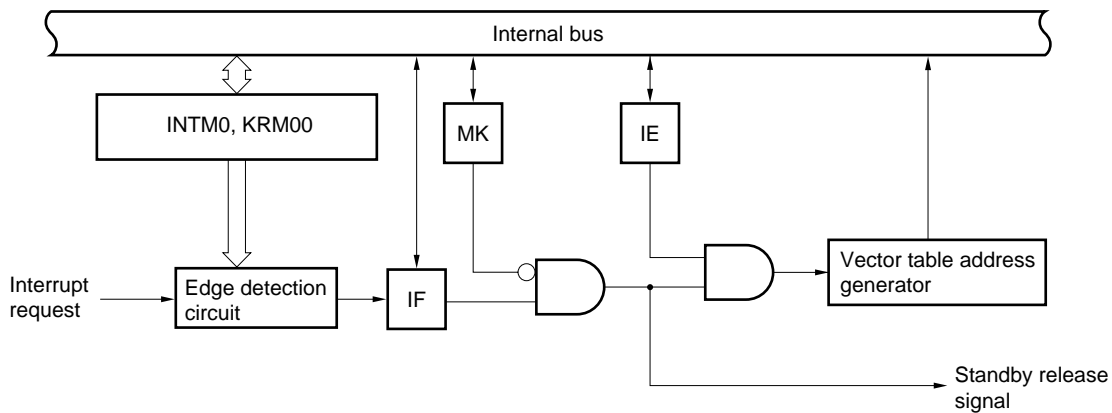

INTM0: External interrupt mode register 0

KRM00: Key return mode register 00

IF: Interrupt request flag

IE: Interrupt enable flag

MK: Interrupt mask flag

7. STANDBY FUNCTIONS

The following two standby functions are available for further reduction of system current consumption.

- HALT mode: In this mode, the CPU operation clock is stopped. The average current consumption can be reduced by intermittent operation by combining this mode with the normal operation mode.
- STOP mode: In this mode, oscillation of the main system clock is stopped. All the operations performed on the main system clock are suspended, resulting in extremely small current consumption.

Figure 7-1. Standby Functions

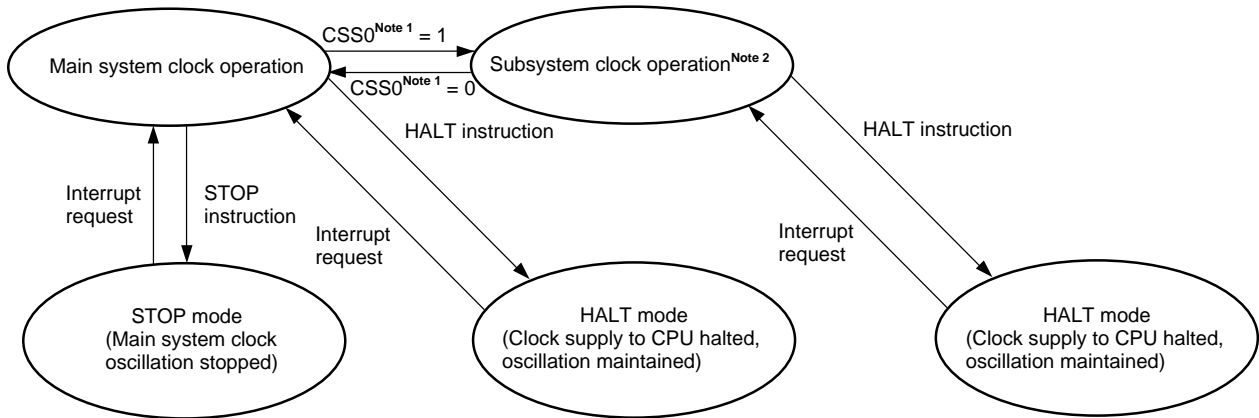

Notes 1. Bit 4 of subclock control register (CSS)

2. The current consumption can be reduced by stopping the main system clock. When the CPU is operating on the subsystem clock, set the bit 7 (MCC) of processor clock control register (PCC) to stop the main system clock. The STOP instruction cannot be used.

Caution When the main system clock is stopped and the device is operating on the subsystem clock, wait until the oscillation stabilization time has been secured by the program before switching back to the main system clock.

8. RESET FUNCTIONS

The following two reset methods are available.

- External reset by $\overline{\text{RESET}}$ signal input
- Internal reset by watchdog timer runaway time detection

9. INSTRUCTION SET OVERVIEW

The instruction set for the μPD789046 is listed later.

9.1 Legend

9.1.1 Operand formats and descriptions

The description made in the operand field of each instruction conforms to the operand format for the instructions listed below (the details conform with the assembler specification). If more than one operand format is listed for an instruction, one is selected. Uppercase letters, #, !, \$, and a pair of [and] are used to specify keywords, which must be written exactly as they appear. The meanings of these special characters are as follows:

- #: Immediate data specification
- \$: Relative address specification
- !: Absolute address specification
- [and]: Indirect address specification

Immediate data should be described using appropriate values or labels. The specification of values and labels must be accompanied by #, !, \$, or a pair of [and].

Operand registers, expressed as r or rp in the formats, can be described using both functional names (X, A, C, etc.) and absolute names (R0, R1, R2, and other names listed in Table 9-1).

Table 9-1. Operand Formats and Descriptions

Format	Description
r rp sfr	X (R0), A (R1), C (R2), B (R3), E (R4), D (R5), L (R6), H (R7) AX (RP0), BC (RP1), DE (RP2), HL (RP3) Special function register symbol
saddr saddrp	FE20H to FF1FH: Immediate data or label FE20H to FF1FH: Immediate data or label (even addresses only)
addr16 addr5	0000H to FFFFH: Immediate data or label (only even addresses for 16-bit data transfer instructions) 0040H to 007FH: Immediate data or label (even addresses only)
word byte bit	16-bit immediate data or label 8-bit immediate data or label 3-bit immediate data or label

9.1.2 Descriptions of operation field

A	: A register; 8-bit accumulator
X	: X register
B	: B register
C	: C register
D	: D register
E	: E register
H	: H register
L	: L register
AX	: AX register pair; 16-bit accumulator
BC	: BC register pair
DE	: DE register pair
HL	: HL register pair
PC	: Program counter
SP	: Stack pointer
PSW	: Program status word
CY	: Carry flag
AC	: Auxiliary carry flag
Z	: Zero flag
IE	: Interrupt request enable flag
NMIS	: Flag to indicate that a non-maskable interrupt is being handled
()	: Contents of a memory location indicated by a parenthesized address or register
X _H , X _L	: Higher and lower 8 bits of a 16-bit register
^	: Logical product (AND)
∨	: Logical sum (OR)
⊕	: Exclusive OR
—	: Inverted data
addr16	: 16-bit immediate data or label
jdisp8	: Signed 8-bit data (displacement value)

9.1.3 Descriptions of flag operation field

(blank)	: No change
0	: To be cleared to 0
1	: To be set to 1
×	: To be set or cleared according to the result
R	: To be restored to the previous value

9.2 Operations

Mnemonic	Operand	Byte	Clock	Operation	Flag			
					Z	AC	CY	
MOV	r, #byte	3	6	$r \leftarrow \text{byte}$				
	saddr, #byte	3	6	$(\text{saddr}) \leftarrow \text{byte}$				
	sfr, #byte	3	6	$\text{sfr} \leftarrow \text{byte}$				
	A, r	Note 1	2	4	$A \leftarrow r$			
	r, A	Note 1	2	4	$r \leftarrow A$			
	A, saddr		2	4	$A \leftarrow (\text{saddr})$			
	saddr, A		2	4	$(\text{saddr}) \leftarrow A$			
	A, sfr		2	4	$A \leftarrow \text{sfr}$			
	sfr, A		2	4	$\text{sfr} \leftarrow A$			
	A, !addr16		3	8	$A \leftarrow (\text{addr16})$			
	!addr16, A		3	8	$(\text{addr16}) \leftarrow A$			
	PSW, #byte		3	6	$\text{PSW} \leftarrow \text{byte}$	×	×	×
	A, PSW		2	4	$A \leftarrow \text{PSW}$			
	PSW, A		2	4	$\text{PSW} \leftarrow A$	×	×	×
	A, [DE]		1	6	$A \leftarrow (\text{DE})$			
	[DE], A		1	6	$(\text{DE}) \leftarrow A$			
	A, [HL]		1	6	$A \leftarrow (\text{HL})$			
	[HL], A		1	6	$(\text{HL}) \leftarrow A$			
	A, [HL + byte]		2	6	$A \leftarrow (\text{HL} + \text{byte})$			
[HL + byte], A		2	6	$(\text{HL} + \text{byte}) \leftarrow A$				
XCH	A, X		1	4	$A \leftrightarrow X$			
	A, r	Note 2	2	6	$A \leftrightarrow r$			
	A, saddr		2	6	$A \leftrightarrow (\text{saddr})$			
	A, sfr		2	6	$A \leftrightarrow (\text{sfr})$			
	A, [DE]		1	8	$A \leftrightarrow (\text{DE})$			
	A, [HL]		1	8	$A \leftrightarrow (\text{HL})$			
	A, [HL + byte]		2	8	$A \leftrightarrow (\text{HL} + \text{byte})$			
MOVW	rp, #word	3	6	$\text{rp} \leftarrow \text{word}$				
	AX, saddrp	2	6	$\text{AX} \leftarrow (\text{saddrp})$				
	saddrp, AX	2	8	$(\text{saddrp}) \leftarrow \text{AX}$				
	AX, rp	Note 3	1	4	$\text{AX} \leftarrow \text{rp}$			
	rp, AX	Note 3	1	4	$\text{rp} \leftarrow \text{AX}$			

- Notes**
1. Except when $r = A$.
 2. Except when $r = A$ or X .
 3. Only when $\text{rp} = \text{BC}, \text{DE},$ or HL .

Remark The instruction clock cycle is based on the CPU clock (f_{CPU}), specified in the processor clock control register (PCC).

Mnemonic	Operand	Byte	Clock	Operation	Flag		
					Z	AC	CY
XCHW	AX, rp ^{Note}	1	8	AX ↔ rp			
ADD	A, #byte	2	4	A, CY ← A + byte	×	×	×
	saddr, #byte	3	6	(saddr), CY ← (saddr) + byte	×	×	×
	A, r	2	4	A, CY ← A + r	×	×	×
	A, saddr	2	4	A, CY ← A + (saddr)	×	×	×
	A, !addr16	3	8	A, CY ← A + (addr16)	×	×	×
	A, [HL]	1	6	A, CY ← A + (HL)	×	×	×
	A, [HL + byte]	2	6	A, CY ← A + (HL + byte)	×	×	×
ADDC	A, #byte	2	4	A, CY ← A + byte + CY	×	×	×
	saddr, #byte	3	6	(saddr), CY ← (saddr) + byte + CY	×	×	×
	A, r	2	4	A, CY ← A + r + CY	×	×	×
	A, saddr	2	4	A, CY ← A + (saddr) + CY	×	×	×
	A, !addr16	3	8	A, CY ← A + (addr16) + CY	×	×	×
	A, [HL]	1	6	A, CY ← A + (HL) + CY	×	×	×
	A, [HL + byte]	2	6	A, CY ← A + (HL + byte) + CY	×	×	×
SUB	A, #byte	2	4	A, CY ← A – byte	×	×	×
	saddr, #byte	3	6	(saddr), CY ← (saddr) – byte	×	×	×
	A, r	2	4	A, CY ← A – r	×	×	×
	A, saddr	2	4	A, CY ← A – (saddr)	×	×	×
	A, !addr16	3	8	A, CY ← A – (addr16)	×	×	×
	A, [HL]	1	6	A, CY ← A – (HL)	×	×	×
	A, [HL + byte]	2	6	A, CY ← A – (HL + byte)	×	×	×
SUBC	A, #byte	2	4	A, CY ← A – byte – CY	×	×	×
	saddr, #byte	3	6	(saddr), CY ← (saddr) – byte – CY	×	×	×
	A, r	2	4	A, CY ← A – r – CY	×	×	×
	A, saddr	2	4	A, CY ← A – (saddr) – CY	×	×	×
	A, !addr16	3	8	A, CY ← A – (addr16) – CY	×	×	×
	A, [HL]	1	6	A, CY ← A – (HL) – CY	×	×	×
	A, [HL + byte]	2	6	A, CY ← A – (HL + byte) – CY	×	×	×
AND	A, #byte	2	4	A ← A ∧ byte	×		
	saddr, #byte	3	6	(saddr) ← (saddr) ∧ byte	×		
	A, r	2	4	A ← A ∧ r	×		
	A, saddr	2	4	A ← A ∧ (saddr)	×		
	A, !addr16	3	8	A ← A ∧ (addr16)	×		
	A, [HL]	1	6	A ← A ∧ (HL)	×		
	A, [HL + byte]	2	6	A ← A ∧ (HL + byte)	×		

Note Only when rp = BC, DE, or HL.

Remark The instruction clock cycle is based on the CPU clock (f_{cpu}), specified in the processor clock control register (PCC).

Mnemonic	Operand	Byte	Clock	Operation	Flag		
					Z	AC	CY
OR	A, #byte	2	4	$A \leftarrow A \vee \text{byte}$	×		
	saddr, #byte	3	6	$(\text{saddr}) \leftarrow (\text{saddr}) \vee \text{byte}$	×		
	A, r	2	4	$A \leftarrow A \vee r$	×		
	A, saddr	2	4	$A \leftarrow A \vee (\text{saddr})$	×		
	A, !addr16	3	8	$A \leftarrow A \vee (\text{addr16})$	×		
	A, [HL]	1	6	$A \leftarrow A \vee (\text{HL})$	×		
	A, [HL + byte]	2	6	$A \leftarrow A \vee (\text{HL} + \text{byte})$	×		
XOR	A, #byte	2	4	$A \leftarrow A \nabla \text{byte}$	×		
	saddr, #byte	3	6	$(\text{saddr}) \leftarrow (\text{saddr}) \nabla \text{byte}$	×		
	A, r	2	4	$A \leftarrow A \nabla r$	×		
	A, saddr	2	4	$A \leftarrow A \nabla (\text{saddr})$	×		
	A, !addr16	3	8	$A \leftarrow A \nabla (\text{addr16})$	×		
	A, [HL]	1	6	$A \leftarrow A \nabla (\text{HL})$	×		
	A, [HL + byte]	2	6	$A \leftarrow A \nabla (\text{HL} + \text{byte})$	×		
CMP	A, #byte	2	4	$A - \text{byte}$	×	×	×
	saddr, #byte	3	6	$(\text{saddr}) - \text{byte}$	×	×	×
	A, r	2	4	$A - r$	×	×	×
	A, saddr	2	4	$A - (\text{saddr})$	×	×	×
	A, !addr16	3	8	$A - (\text{addr16})$	×	×	×
	A, [HL]	1	6	$A - (\text{HL})$	×	×	×
	A, [HL + byte]	2	6	$A - (\text{HL} + \text{byte})$	×	×	×
ADDW	AX, #word	3	6	$\text{AX}, \text{CY} \leftarrow \text{AX} + \text{word}$	×	×	×
SUBW	AX, #word	3	6	$\text{AX}, \text{CY} \leftarrow \text{AX} - \text{word}$	×	×	×
CMPW	AX, #word	3	6	$\text{AX} - \text{word}$	×	×	×
INC	r	2	4	$r \leftarrow r + 1$	×	×	
	saddr	2	4	$(\text{saddr}) \leftarrow (\text{saddr}) + 1$	×	×	
DEC	r	2	4	$r \leftarrow r - 1$	×	×	
	saddr	2	4	$(\text{saddr}) \leftarrow (\text{saddr}) - 1$	×	×	
INCW	rp	1	4	$\text{rp} \leftarrow \text{rp} + 1$			
DECW	rp	1	4	$\text{rp} \leftarrow \text{rp} - 1$			
ROR	A, 1	1	2	$(\text{CY}, A_7 \leftarrow A_0, A_{m-1} \leftarrow A_m) \times 1$			×
ROL	A, 1	1	2	$(\text{CY}, A_0 \leftarrow A_7, A_{m+1} \leftarrow A_m) \times 1$			×
RORC	A, 1	1	2	$(\text{CY} \leftarrow A_0, A_7 \leftarrow \text{CY}, A_{m-1} \leftarrow A_m) \times 1$			×
ROLC	A, 1	1	2	$(\text{CY} \leftarrow A_7, A_0 \leftarrow \text{CY}, A_{m+1} \leftarrow A_m) \times 1$			×

Remark The instruction clock cycle is based on the CPU clock (f_{CPU}), specified in the processor clock control register (PCC).

Mnemonic	Operand	Byte	Clock	Operation	Flag		
					Z	AC	CY
SET1	saddr. bit	3	6	(saddr. bit) ← 1			
	sfr. bit	3	6	sfr. bit ← 1			
	A. bit	2	4	A. bit ← 1			
	PSW. bit	3	6	PSW. bit ← 1	×	×	×
	[HL]. bit	2	10	(HL). bit ← 1			
CLR1	saddr. bit	3	6	(saddr. bit) ← 0			
	sfr. bit	3	6	sfr. bit ← 0			
	A. bit	2	4	A. bit ← 0			
	PSW. bit	3	6	PSW. bit ← 0	×	×	×
	[HL]. bit	2	10	(HL). bit ← 0			
SET1	CY	1	2	CY ← 1			1
CLR1	CY	1	2	CY ← 0			0
NOT1	CY	1	2	CY ← \overline{CY}			×
CALL	!addr16	3	6	(SP - 1) ← (PC + 3) _H , (SP - 2) ← (PC + 3) _L , PC ← addr16, SP ← SP - 2			
CALLT	[addr5]	1	8	(SP - 1) ← (PC + 1) _H , (SP - 2) ← (PC + 1) _L , PC _H ← (00000000, addr5 + 1), PC _L ← (00000000, addr5), SP ← SP - 2			
RET		1	6	PC _H ← (SP + 1), PC _L ← (SP), SP ← SP + 2			
RETI		1	8	PC _H ← (SP + 1), PC _L ← (SP), PSW ← (SP + 2), SP ← SP + 3, NMIS ← 0	R	R	R
PUSH	PSW	1	2	(SP - 1) ← PSW, SP ← SP - 1			
	rp	1	4	(SP - 1) ← rp _H , (SP - 2) ← rp _L , SP ← SP - 2			
POP	PSW	1	4	PSW ← (SP), SP ← SP + 1	R	R	R
	rp	1	6	rp _H ← (SP + 1), rp _L ← (SP), SP ← SP + 2			
MOVW	SP, AX	2	8	SP ← AX			
	AX, SP	2	6	AX ← SP			
BR	!addr16	3	6	PC ← addr16			
	\$addr16	2	6	PC ← PC + 2 + jdisp8			
	AX	1	6	PC _H ← A, PC _L ← X			

Remark The instruction clock cycle is based on the CPU clock (f_{cpu}), specified in the processor clock control register (PCC).

Mnemonic	Operand	Byte	Clock	Operation	Flag		
					Z	AC	CY
BC	\$addr16	2	6	PC ← PC + 2 + jdisp8 if CY = 1			
BNC	\$addr16	2	6	PC ← PC + 2 + jdisp8 if CY = 0			
BZ	\$addr16	2	6	PC ← PC + 2 + jdisp8 if Z = 1			
BNZ	\$addr16	2	6	PC ← PC + 2 + jdisp8 if Z = 0			
BT	saddr. bit, \$addr16	4	10	PC ← PC + 4 + jdisp8 if (saddr. bit) = 1			
	sfr. bit, \$addr16	4	10	PC ← PC + 4 + jdisp8 if sfr. bit = 1			
	A. bit, \$addr16	3	8	PC ← PC + 3 + jdisp8 if A. bit = 1			
	PSW. bit, \$addr16	4	10	PC ← PC + 4 + jdisp8 if PSW. bit = 1			
BF	saddr. bit, \$addr16	4	10	PC ← PC + 4 + jdisp8 if (saddr. bit) = 0			
	sfr. bit, \$addr16	4	10	PC ← PC + 4 + jdisp8 if sfr. bit = 0			
	A. bit, \$addr16	3	8	PC ← PC + 3 + jdisp8 if A. bit = 0			
	PSW. bit, \$addr16	4	10	PC ← PC + 4 + jdisp8 if PSW. bit = 0			
DBNZ	B, \$addr16	2	6	B ← B - 1, then PC ← PC + 2 + jdisp8 if B ≠ 0			
	C, \$addr16	2	6	C ← C - 1, then PC ← PC + 2 + jdisp8 if C ≠ 0			
	saddr, \$addr16	3	8	(saddr) ← (saddr) - 1, then PC ← PC + 3 + jdisp8 if (saddr) ≠ 0			
NOP		1	2	No Operation			
EI		3	6	IE ← 1 (Enable Interrupt)			
DI		3	6	IE ← 0 (Disable Interrupt)			
HALT		1	2	Set HALT Mode			
STOP		1	2	Set STOP Mode			

Remark The instruction clock cycle is based on the CPU clock (f_{cpu}), specified in the processor clock control register (PCC).

★ 10. ELECTRICAL SPECIFICATIONS

Absolute Maximum Ratings ($T_A = 25^\circ\text{C}$)

Parameter	Symbol	Conditions	Ratings	Unit
Supply voltage	V_{DD}		-0.3 to +6.5	V
Input voltage	V_I		-0.3 to $V_{DD} + 0.3$	V
Output voltage	V_O		-0.3 to $V_{DD} + 0.3$	V
Output current, high	I_{OH}	Per pin	-10	mA
		Total for all pins	-30	mA
Output current, low	I_{OL}	Per pin	30	mA
		Total for all pins	160	mA
Operating ambient temperature	T_A		-40 to +85	$^\circ\text{C}$
Storage temperature	T_{stg}		-65 to +150	$^\circ\text{C}$

Caution Product quality may suffer if the absolute maximum rating is exceeded even momentarily for any parameter. That is, the absolute maximum ratings are rated values at which the product is on the verge of suffering physical damage, and therefore the product must be used under conditions that ensure that the absolute maximum ratings are not exceeded.

Remark Unless specified otherwise, the characteristics of alternate-function pins are the same as those of port pins.

Main System Clock Oscillator Characteristics (T_A = -40 to +85°C, V_{DD} = 1.8 to 5.5 V)

Resonator	Recommended Circuit	Parameter	Conditions	MIN.	TYP.	MAX.	Unit
Ceramic resonator		Oscillation frequency (f _x) ^{Note 1}	V _{DD} = oscillation voltage range	1.0		5.0	MHz
		Oscillation stabilization time ^{Note 2}	After V _{DD} reaches oscillation voltage range MIN.			4	ms
Crystal resonator		Oscillation frequency (f _x) ^{Note 1}		1.0		5.0	MHz
		Oscillation stabilization time ^{Note 2}	V _{DD} = 4.5 to 5.5 V			10 30	ms
External clock		X1 input frequency (f _x) ^{Note 1}		1.0		5.0	MHz
		X1 input high-/low-level width (t _{xH} , t _{xL})		85		500	ns
		X1 input frequency (f _x) ^{Note 1}	V _{DD} = 2.7 to 5.5 V	1.0		5.0	MHz
		X1 input high-/low-level width (t _{xH} , t _{xL})	V _{DD} = 2.7 to 5.5 V	85		500	ns

- Notes**
1. Indicates only oscillator characteristics. Refer to AC Characteristics for instruction execution time.
 2. Time required to stabilize oscillation after reset or STOP mode release. Use the resonator that stabilizes oscillation within the oscillation wait time.

Cautions 1. When using the main system clock oscillator, wire as follows in the area enclosed by the broken lines in the above figures to avoid an adverse effect from wiring capacitance.

- Keep the wiring length as short as possible.
- Do not cross the wiring with the other signal lines.
- Do not route the wiring near a signal line through which a high fluctuating current flows.
- Always make the ground point of the oscillator capacitor the same potential as V_{SS0}.
- Do not ground the capacitor to a ground pattern through which a high current flows.
- Do not fetch signals from the oscillator.

2. When the main system clock is stopped and the device is operating on the subsystem clock, wait until the oscillation stabilization time has been secured by the program before switching back to the main system clock.

Subsystem Clock Oscillator Characteristics (T_A = -40 to +85°C, V_{DD} = 1.8 to 5.5 V)

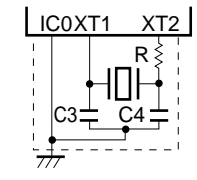
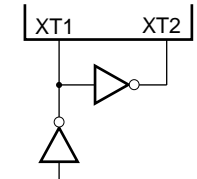
Resonator	Recommended Circuit	Parameter	Conditions	MIN.	TYP.	MAX.	Unit
Crystal resonator		Oscillation frequency (f _{XT}) ^{Note 1}		32	32.768	35	kHz
		Oscillation stabilization time ^{Note 2}	V _{DD} = 4.5 to 5.5 V		1.2	2	s
External clock		XT1 input frequency (f _{XT}) ^{Note 1}		32		35	kHz
		XT1 input high-/low-level width (t _{XTH} , t _{XTL})		14.3		15.6	μs

- Notes**
1. Indicates only oscillator characteristics. Refer to AC Characteristics for instruction execution time.
 2. Time required to stabilize oscillation after reset or STOP mode release. Use the resonator that stabilizes oscillation within the oscillation wait time.

Cautions

1. When using the subsystem clock oscillator, wire as follows in the area enclosed by the broken lines in the above figure to avoid an adverse effect from wiring capacitance.

- Keep the wiring length as short as possible.
- Do not cross the wiring with the other signal lines.
- Do not route the wiring near a signal line through which a high fluctuating current flows.
- Always make the ground point of the oscillator capacitor the same potential as V_{SS0}.
- Do not ground the capacitor to a ground pattern through which a high current flows.
- Do not fetch signals from the oscillator.

2. The subsystem clock oscillator is designed as a low-amplitude circuit for reducing current consumption, and is more prone to malfunction due to noise than the main system clock oscillator. Particular care is therefore required with the wiring method when the subsystem clock is used.

DC Characteristics (T_A = -40 to +85°C, V_{DD} = 1.8 to 5.5 V)

Parameter	Symbol	Conditions		MIN.	TYP.	MAX.	Unit
Output current, high	I _{OH}	Per pin				-1	mA
		Total for all pins				-15	mA
Output current, low	I _{OL}	Per pin				10	mA
		Total for all pins				80	mA
Input voltage, high	V _{IH1}	P00 to P07, P10 to P17, P30, P31	V _{DD} = 2.7 to 5.5 V	0.7V _{DD}		V _{DD}	V
				0.9V _{DD}		V _{DD}	V
	V _{IH2}	RESET, P20 to P27, P40 to P47	V _{DD} = 2.7 to 5.5 V	0.8V _{DD}		V _{DD}	V
				0.9V _{DD}		V _{DD}	V
	V _{IH3}	X1, X2	V _{DD} = 4.5 to 5.5 V	V _{DD} - 0.5		V _{DD}	V
				V _{DD} - 0.1		V _{DD}	V
	V _{IH4}	XT1, XT2	V _{DD} = 4.5 to 5.5 V	V _{DD} - 0.5		V _{DD}	V
				V _{DD} - 0.1		V _{DD}	V
Input voltage, low	V _{IL1}	P00 to P07, P10 to P17, P30, P31	V _{DD} = 2.7 to 5.5 V	0		0.3V _{DD}	V
				0		0.1V _{DD}	V
	V _{IL2}	RESET, P20 to P27, P40 to P47	V _{DD} = 2.7 to 5.5 V	0		0.2V _{DD}	V
				0		0.1V _{DD}	V
	V _{IL3}	X1, X2	V _{DD} = 4.5 to 5.5 V	0		0.4	V
				0		0.1	V
	V _{IL4}	XT1, XT2	V _{DD} = 4.5 to 5.5 V	0		0.4	V
				0		0.1	V
Output voltage, high	V _{OH}	V _{DD} = 4.5 to 5.5 V, I _{OH} = -1 mA		V _{DD} - 1.0			V
		I _{OH} = -100 μA		V _{DD} - 0.5			V
Output voltage, low	V _{OL}	V _{DD} = 4.5 to 5.5 V, I _{OL} = 10 mA				1.0	V
		I _{OL} = 400 μA				0.5	V
Input leakage current, high	I _{LIH1}	V _{IN} = V _{DD}	Pins other than X1, X2, XT1, XT2			3	μA
	I _{LIH2}			X1, X2, XT1, XT2			20
Input leakage current, low	I _{LIL1}	V _{IN} = 0 V	Pins other than X1, X2, XT1, XT2			-3	μA
	I _{LIL2}			X1, X2, XT1, XT2			-20
Output leakage current, high	I _{LOH}	V _{OUT} = V _{DD}				3	μA
Output leakage current, low	I _{LOL}	V _{OUT} = 0 V				-3	μA
Software pull-up resistor	R	V _{IN} = 0 V		50	100	200	kΩ

Remark Unless specified otherwise, the characteristics of alternate-function pins are the same as those of port pins.

DC Characteristics (T_A = -40 to +85°C, V_{DD} = 1.8 to 5.5 V)

Parameter	Symbol	Conditions	MIN.	TYP.	MAX.	Unit	
Power supply current ^{Note 1}	I _{DD1}	5.0-MHz crystal oscillation operating mode (C1 = C2 = 22 pF)	V _{DD} = 5.0 V ±10% ^{Note 3}		1.8	3.2	mA
			V _{DD} = 3.0 V ±10% ^{Note 4}		0.45	0.9	mA
			V _{DD} = 2.0 V ±10% ^{Note 4}		0.25	0.45	mA
	I _{DD2}	5.0-MHz crystal oscillation HALT mode (C1 = C2 = 22 pF)	V _{DD} = 5.0 V ±10% ^{Note 3}		0.8	1.6	mA
			V _{DD} = 3.0 V ±10% ^{Note 4}		0.3	0.6	mA
			V _{DD} = 2.0 V ±10% ^{Note 4}		0.15	0.3	mA
	I _{DD3}	32.768-kHz crystal oscillation operating mode ^{Note 2} (C3 = C4 = 22 pF, R = 220 kΩ)	V _{DD} = 5.0 V ±10%		70	160	μA
			V _{DD} = 3.0 V ±10%		40	90	μA
			V _{DD} = 2.0 V ±10%		25	60	μA
	I _{DD4}	32.768-kHz crystal oscillation HALT mode ^{Note 2} (C3 = C4 = 22 pF, R = 220 kΩ)	V _{DD} = 5.0 V ±10%		20	55	μA
			V _{DD} = 3.0 V ±10%		5	25	μA
			V _{DD} = 2.0 V ±10%		2.5	12.5	μA
I _{DD5}	STOP mode	V _{DD} = 5.0 V ±10%		0.1	10	μA	
		V _{DD} = 3.0 V ±10%		0.05	5.0	μA	
		T _A = 25°C		0.05	3.0	μA	
		V _{DD} = 2.0 V ±10%		0.05	3.0	μA	

- Notes**
1. The port current (including the current flowing through the on-chip pull-up resistor) is not included.
 2. When the main system clock is stopped
 3. High-speed mode operation (when processor clock control register (PCC) is set to 00H)
 4. Low-speed mode operation (when PCC is set to 02H)

Remark Unless specified otherwise, the characteristics of alternate-function pins are the same as those of port pins.

AC Characteristics

(1) Basic operation (T_A = -40 to +85°C, V_{DD} = 1.8 to 5.5 V)

Parameter	Symbol	Conditions	MIN.	TYP.	MAX.	Unit	
Cycle time (Minimum instruction execution time)	T _{CY}	Operating with main system clock	V _{DD} = 2.7 to 5.5 V	0.4		8	μs
				1.6		8	μs
		Operating with subsystem clock	114	122	125	μs	
TI80 input frequency	f _{TI}	V _{DD} = 2.7 to 5.5 V		0	4	MHz	
				0	275	kHz	
TI80 input high- /low-level width	t _{TIH} , t _{TIL}	V _{DD} = 2.7 to 5.5 V		0.1		μs	
				1.8		μs	
Interrupt input high- /low-level width	t _{INTH} , t _{INTL}	INTP0 to INTP2	10			μs	
RESET input low-level width	t _{RSL}		10			μs	

T_{CY} vs V_{DD} (main system clock)

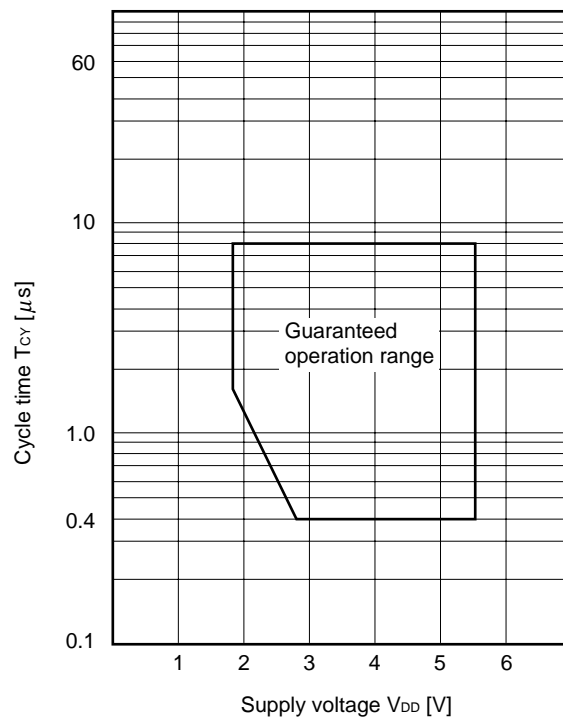

(2) Serial interface

(a) 3-wire serial I/O mode ($\overline{\text{SCK20}}$...Internal clock)

Parameter	Symbol	Conditions	MIN.	TYP.	MAX.	Unit
$\overline{\text{SCK20}}$ cycle time	t_{KCY1}	$V_{\text{DD}} = 2.7 \text{ to } 5.5 \text{ V}$	800			ns
			3,200			ns
$\overline{\text{SCK20}}$ high-/low-level width	$t_{\text{KH1}}, t_{\text{KL1}}$	$V_{\text{DD}} = 2.7 \text{ to } 5.5 \text{ V}$	$t_{\text{KCY1}}/2-50$			ns
			$t_{\text{KCY1}}/2-150$			ns
SI20 setup time (to $\overline{\text{SCK20}}$ ↑)	t_{SIK1}	$V_{\text{DD}} = 2.7 \text{ to } 5.5 \text{ V}$	150			ns
			500			ns
SI20 hold time (from $\overline{\text{SCK20}}$ ↑)	t_{KSI1}	$V_{\text{DD}} = 2.7 \text{ to } 5.5 \text{ V}$	400			ns
			600			ns
SO20 output delay time from $\overline{\text{SCK20}}$ ↓	t_{KSO1}	R = 1 kΩ, C = 100 pF ^{Note}	$V_{\text{DD}} = 2.7 \text{ to } 5.5 \text{ V}$		250	ns
				0	1,000	ns

Note R and C are the load resistance and load capacitance of the SO20 output line.

(b) 3-wire serial I/O mode ($\overline{\text{SCK20}}$...External clock)

Parameter	Symbol	Conditions	MIN.	TYP.	MAX.	Unit
$\overline{\text{SCK20}}$ cycle time	t_{KCY2}	$V_{\text{DD}} = 2.7 \text{ to } 5.5 \text{ V}$	900			ns
			3,500			ns
$\overline{\text{SCK20}}$ high-/low-level width	$t_{\text{KH2}}, t_{\text{KL2}}$	$V_{\text{DD}} = 2.7 \text{ to } 5.5 \text{ V}$	400			ns
			1,600			ns
SI20 setup time (to $\overline{\text{SCK20}}$ ↑)	t_{SIK2}	$V_{\text{DD}} = 2.7 \text{ to } 5.5 \text{ V}$	100			ns
			150			ns
SI20 hold time (from $\overline{\text{SCK20}}$ ↑)	t_{KSI2}	$V_{\text{DD}} = 2.7 \text{ to } 5.5 \text{ V}$	400			ns
			600			ns
SO20 output delay time from $\overline{\text{SCK20}}$ ↓	t_{KSO2}	R = 1 kΩ, C = 100 pF ^{Note}	$V_{\text{DD}} = 2.7 \text{ to } 5.5 \text{ V}$		300	ns
				0	1,000	ns

Note R and C are the load resistance and load capacitance of the SO20 output line.

(c) UART mode (Dedicated baud rate generator output)

Parameter	Symbol	Conditions	MIN.	TYP.	MAX.	Unit
Transfer rate		$V_{\text{DD}} = 2.7 \text{ to } 5.5 \text{ V}$			78,125	bps
					19,531	bps

(d) UART mode (External clock input)

Parameter	Symbol	Conditions	MIN.	TYP.	MAX.	Unit
ASCK20 cycle time	t _{KCY3}	V _{DD} = 2.7 to 5.5 V	900			ns
			3,500			ns
ASCK20 high-/low-level width	t _{KH3} , t _{KL3}	V _{DD} = 2.7 to 5.5 V	400			ns
			1,600			ns
Transfer rate		V _{DD} = 2.7 to 5.5 V			39,063	bps
					9,766	bps
ASCK20 rise/fall time	t _r , t _f				1	μs

AC Timing Test Points (excluding X1 and XT1 inputs)

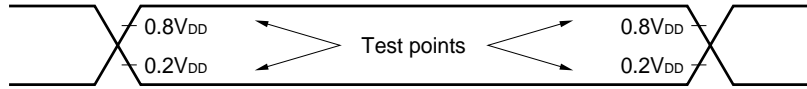

Clock Timing

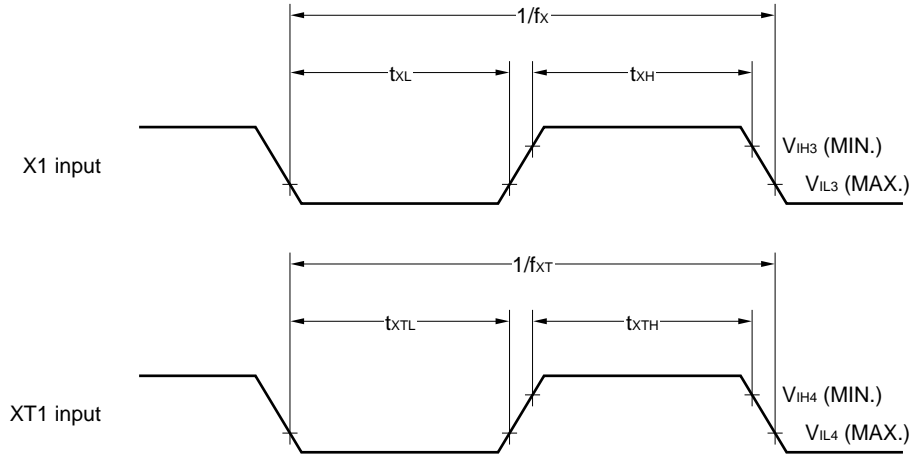

TI Timing

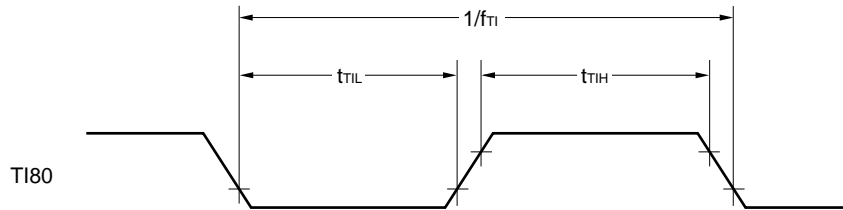

Interrupt Input Timing

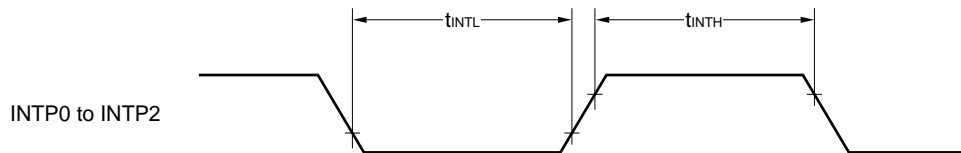

RESET Input Timing

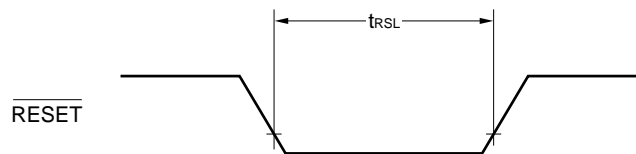

Serial Transfer Timing

3-wire serial I/O mode:

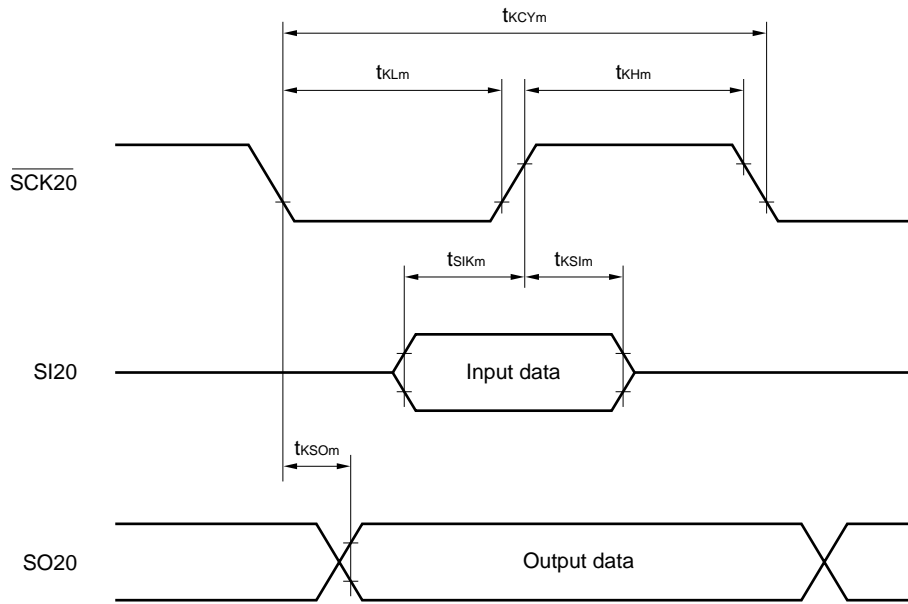

Remark $m = 1, 2$

UART mode (external clock input):

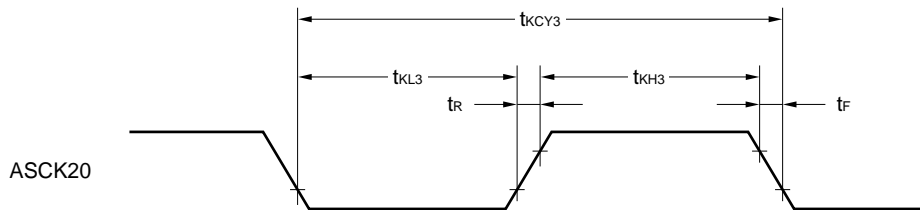

Data Memory STOP Mode Low Supply Voltage Data Retention Characteristics (T_A = -40 to +85°C)

Parameter	Symbol	Conditions	MIN.	TYP.	MAX.	Unit
Data retention power supply voltage	V _{DDDR}		1.8		5.5	V
Release signal set time	t _{SREL}		0			μs
Oscillation stabilization wait time ^{Note 1}	t _{WAIT}	Release by $\overline{\text{RESET}}$		2 ¹⁵ /f _x		ms
		Release by interrupt request		Note 2		ms

- Notes**
- Oscillation stabilization wait time is a time for stopping the CPU operation to prevent the unstable operation when the oscillation is started.
 - Selection of 2¹²/f_x, 2¹⁵/f_x, and 2¹⁷/f_x is possible with bits 0 to 2 (OSTS0 to OSTS2) of the oscillation stabilization time select register (OSTS).

Remark f_x: Main system clock oscillation frequency

Data Retention Timing (STOP mode release by $\overline{\text{RESET}}$)

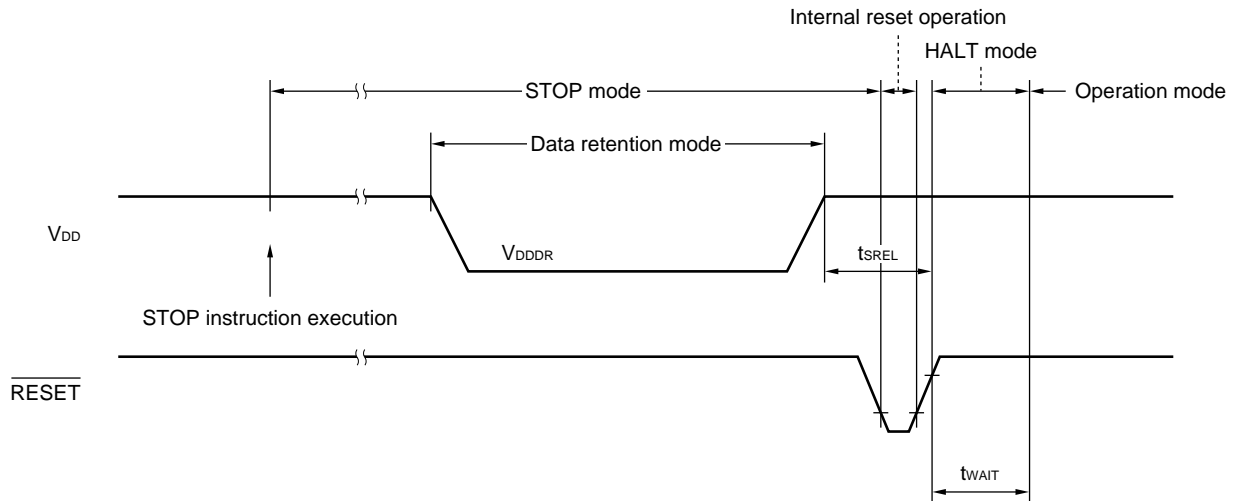

Data Retention Timing (Standby release signal: STOP mode release by interrupt signal)

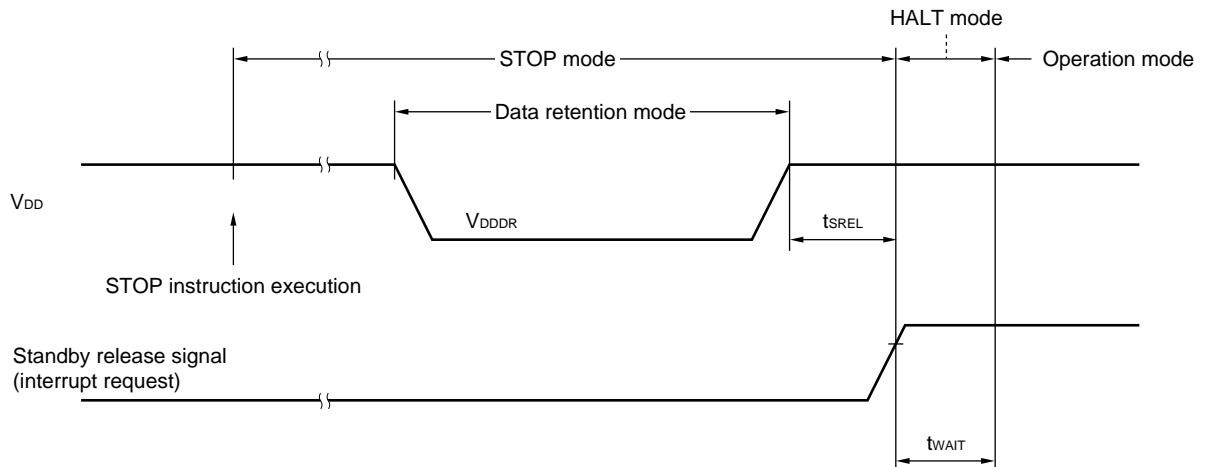

★ 11. CHARACTERISTICS CURVES

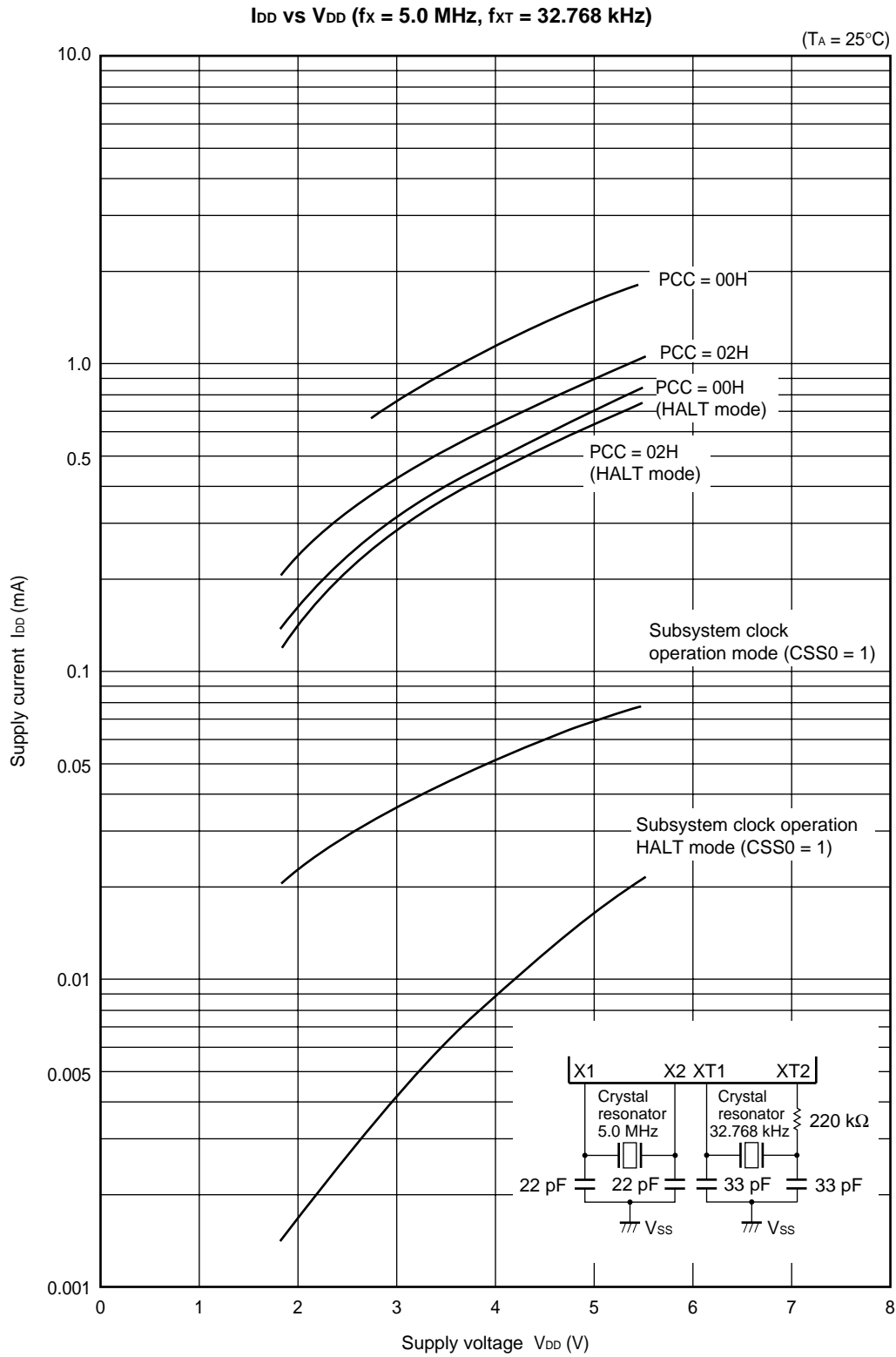

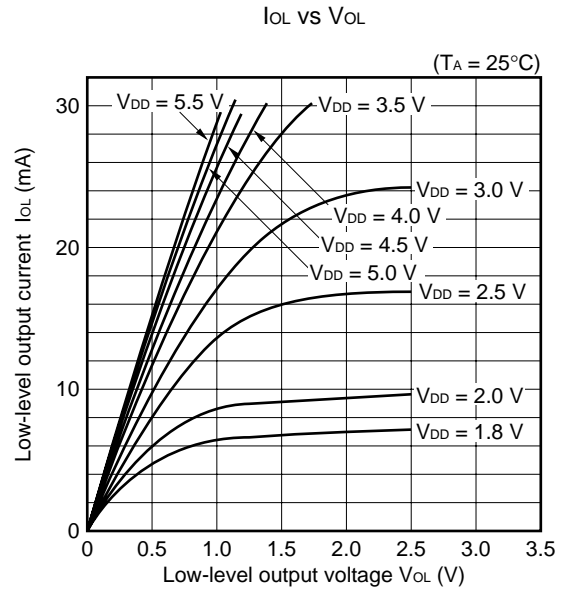
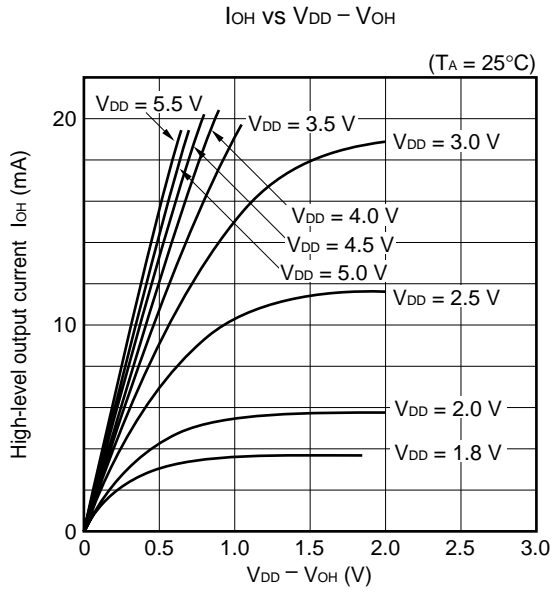

★ 12. PACKAGE DRAWING

44 PIN PLASTIC QFP (10x10)

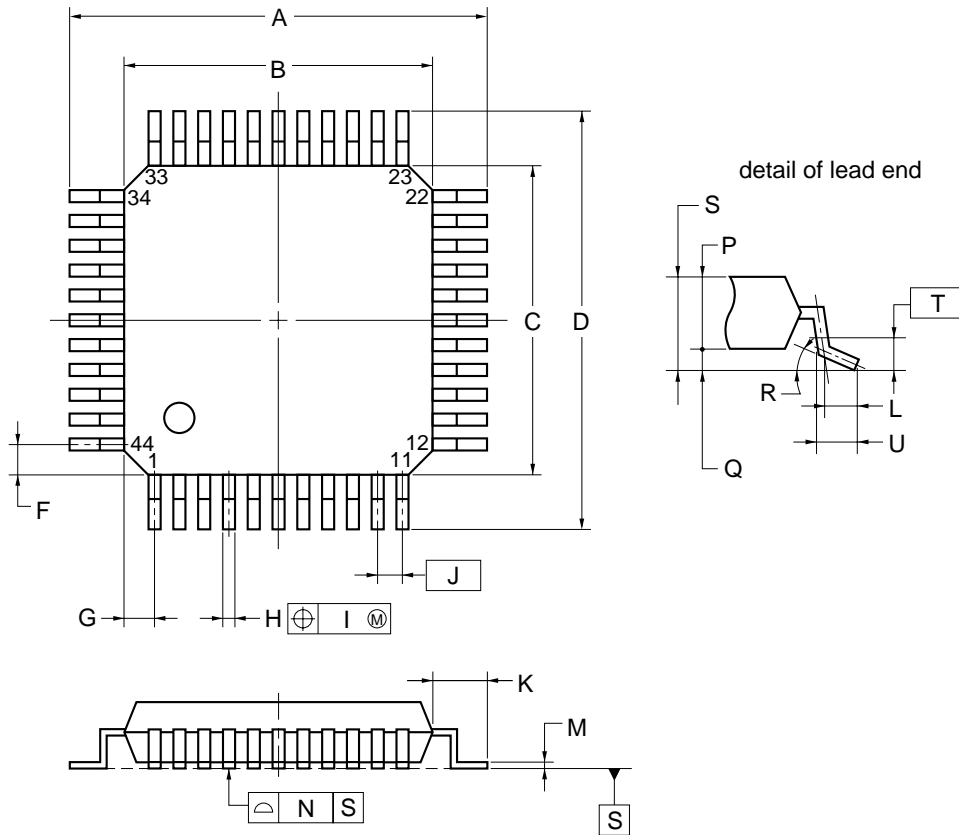

NOTE
 Each lead centerline is located within 0.16 mm of its true position (T.P.) at maximum material condition.

ITEM	MILLIMETERS
A	12.0±0.2
B	10.0±0.2
C	10.0±0.2
D	12.0±0.2
F	1.0
G	1.0
H	0.37 ^{+0.08} _{-0.07}
I	0.2
J	0.8 (T.P.)
K	1.0±0.2
L	0.5
M	0.17 ^{+0.03} _{-0.06}
N	0.10
P	1.4±0.05
Q	0.1±0.05
R	3°+4° -3°
S	1.6 MAX.
U	0.6±0.15

S44GB-80-8ES-1

★ 13. RECOMMENDED SOLDERING CONDITIONS

The μPD789046 should be soldered and mounted under the following recommended conditions.

For the details of the recommended soldering conditions, refer to the document **Semiconductor Device Mounting Technology Manual (C10535E)**.

For soldering methods and conditions other than those recommended below, contact your NEC sales representative.

Table 13-1. Surface Mounting Type Soldering Conditions

μPD789046GB-xxx-8ES: 44-pin plastic LQFP (10 × 10 mm)

Soldering Method	Soldering Conditions	Recommended Condition Symbol
Infrared reflow	Package peak temperature: 235°C, Time: 30 sec. Max. (at 210°C or higher), Count: two times or less	IR35-00-2
VPS	Package peak temperature: 215°C, Time: 40 sec. Max. (at 200°C or higher), Count: two times or less	VP15-00-2
Wave soldering	Solder bath temperature: 260°C Max., Time: 10 sec. Max., Count: once, Preheating temperature: 120°C Max. (package surface temperature)	WS60-00-1
Partial heating	Pin temperature: 300°C Max., Time: 3 sec. Max. (per pin row)	—

Caution Do not use different soldering methods together (except for partial heating).

APPENDIX A. DEVELOPMENT TOOLS

The following development tools are available for system development using the μPD789046.

Language Processing Software

RA78K0S ^{Notes 1, 2, 3}	Assembler package common to 78K/0S Series
CC78K0S ^{Notes 1, 2, 3}	C compiler package common to 78K/0S Series
DF789046 ^{Notes 1, 2, 3}	Device file for μPD789046 Subseries
CC78K0S-L ^{Notes 1, 2, 3}	C compiler library source file common to 78K/0S Series

★ **Flash Memory Writing Tools**

Flashpro III (Part No. FL-PR3 ^{Note 4} , PG-FP3)	Flash programmer dedicated to on-chip flash memory microcontroller
FA-44GB-8ES ^{Note 4}	Flash memory writing adapter for 44-pin plastic LQFP (GB-8ES type)

- Notes**
1. Based on the PC-9800 series (MS-DOS™ + Windows)
 2. Based on the IBM PC/AT and compatibles (Japanese/English Windows)
 3. Based on the HP9000 series 700™ (HP-UX™), SPARCstation™ (SunOS™, Solaris™), and NEWS™ (NEWS-OS™)
 4. Products made by NAITO DENSEI MACHIDA MFG. CO., LTD. (+81-44-822-3813). Contact an NEC distributor regarding the purchase of these products.

Remark The RA78K0S and CC78K0S are used in combination with the DF789046.

Debugging Tools

IE-78K0S-NS In-circuit emulator	This in-circuit emulator is used to debug hardware or software when application systems which use the 78K/0S Series are developed. The IE-78K0S-NS supports the integrated debugger (ID78K0S-NS). The IE-78K0S-NS is used in combination with an interface adapter for connection to an AC adapter, emulation probe, or host machine.
IE-70000-MC-PS-B AC adapter	This adapter is used to supply power from a 100 to 240 V AC outlet.
IE-70000-98-IF-C Interface adapter	This adapter is required when a PC-9800 series PC (except notebook type) is used as the host machine for the IE-78K0S-NS (C bus supported).
★ IE-70000-CD-IF-A PC card/interface	These PC card and interface cable are required when a notebook PC is used as the host machine for the IE-78K0S-NS (PCMCIA socket supported).
IE-70000-PC-IF-C Interface adapter	This adapter is required when an IBM PC/AT™ or compatible is used as the host machine for the IE-78K0S-NS (ISA bus supported).
★ IE-70000-PCI-IF Interface adapter	This adapter is required when a PCI bus incorporated personal computer is used as the host machine for the IE-78K0S-NS.
IE-789046-NS-EM1 Emulation board	This board is used to emulate the peripheral hardware specific to the device. The IE-789046-NS-EM1 is used in combination with the in-circuit emulator.
★ NP-44GB ^{Note 3} NP-44GB-TQ ^{Note 3}	This board is used to connect an in-circuit emulator to the target system. The board is dedicated to the 44-pin plastic LQFP (GB-8ES type).
SM78K0S ^{Notes 1, 2}	System simulator common to 78K/0S Series
ID78K0S-NS ^{Notes 1, 2}	Integrated debugger common to 78K/0S Series
DF789046 ^{Notes 1, 2}	Device file for μPD789046 Subseries

Real-time OS

MX78K0S ^{Notes 1, 2}	OS for 78K/0S Series
-------------------------------	----------------------

- Notes**
1. Based on the PC-9800 series (MS-DOS + Windows)
 2. Based on the IBM PC/AT and compatibles (Japanese/English Windows)
 3. Products made by NAITO DENSEI MACHIDA MFG. CO., LTD. (+81-44-822-3813). Contact an NEC distributor regarding the purchase of these products.

Remark The SM78K0S is used in combination with the DF789046.

APPENDIX B. RELATED DOCUMENTS

Documents Related to Devices

Document Name	Document No.	
	Japanese	English
μPD789046 Data Sheet	U13380J	This manual
μPD78F9046 Preliminary Product Information	U13546J	U13546E
μPD789046 Subseries User's Manual	U13600J	U13600E
78K/0S Series Instructions User's Manual	U11047J	U11047E

Documents Related to Development Tools (User's Manuals)

Document Name		Document No.	
		Japanese	English
RA78K0S Assembler Package	Operation	U11622J	U11622E
	Assembly Language	U11599J	U11599E
	Structured Assembly Language	U11623J	U11623E
CC78K0S C Compiler	Operation	U11816J	U11816E
	Language	U11817J	U11817E
SM78K0S System Simulator Windows Based	Reference	U11489J	U11489E
SM78K Series System Simulator	External Part User Open Interface Specifications	U10092J	U10092E
ID78K0S-NS Integrated Debugger Windows Based	Reference	U12901J	U12901E
★ IE-78K0S-NS In-circuit Emulator		U13549J	U13549E
IE-789046-NS-EM1 Emulation Board		To be prepared	To be prepared

Documents Related to Embedded Software (User's Manuals)

Document Name		Document No.	
		Japanese	English
78K/0S Series OS MX78K0S	Fundamental	U12938J	U12938E

Caution The related documents listed above are subject to change without notice. Be sure to use the latest version of each document for designing.

Other Related Documents

	Document Name	Document No.	
		Japanese	English
★	SEMICONDUCTORS SELECTION GUIDE Products & Packages (CD-ROM)	X13769X	
	Semiconductor Device Mounting Technology Manual	C10535J	C10535E
	Quality Grades on NEC Semiconductor Devices	C11531J	C11531E
	NEC Semiconductor Device Reliability/Quality Control System	C10983J	C10983E
	Guide to Prevent Damage for Semiconductor Devices by Electrostatic Discharge (ESD)	C11892J	C11892E
	Guide to Microcomputer-Related Products by Third Party	U11416J	-

Caution The related documents listed above are subject to change without notice. Be sure to use the latest version of each document for designing.

NOTES FOR CMOS DEVICES**① PRECAUTION AGAINST ESD FOR SEMICONDUCTORS**

Note:

Strong electric field, when exposed to a MOS device, can cause destruction of the gate oxide and ultimately degrade the device operation. Steps must be taken to stop generation of static electricity as much as possible, and quickly dissipate it once, when it has occurred. Environmental control must be adequate. When it is dry, humidifier should be used. It is recommended to avoid using insulators that easily build static electricity. Semiconductor devices must be stored and transported in an anti-static container, static shielding bag or conductive material. All test and measurement tools including work bench and floor should be grounded. The operator should be grounded using wrist strap. Semiconductor devices must not be touched with bare hands. Similar precautions need to be taken for PW boards with semiconductor devices on it.

② HANDLING OF UNUSED INPUT PINS FOR CMOS

Note:

No connection for CMOS device inputs can be cause of malfunction. If no connection is provided to the input pins, it is possible that an internal input level may be generated due to noise, etc., hence causing malfunction. CMOS devices behave differently than Bipolar or NMOS devices. Input levels of CMOS devices must be fixed high or low by using a pull-up or pull-down circuitry. Each unused pin should be connected to V_{DD} or GND with a resistor, if it is considered to have a possibility of being an output pin. All handling related to the unused pins must be judged device by device and related specifications governing the devices.

③ STATUS BEFORE INITIALIZATION OF MOS DEVICES

Note:

Power-on does not necessarily define initial status of MOS device. Production process of MOS does not define the initial operation status of the device. Immediately after the power source is turned ON, the devices with reset function have not yet been initialized. Hence, power-on does not guarantee out-pin levels, I/O settings or contents of registers. Device is not initialized until the reset signal is received. Reset operation must be executed immediately after power-on for devices having reset function.

EEPROM is a trademark of NEC Corporation.

MS-DOS and Windows are either registered trademarks or trademarks of Microsoft Corporation in the United States and/or other countries.

PC/AT is a trademark of International Business Machines Corporation.

HP9000 series 700 and HP-UX are trademarks of Hewlett-Packard Company.

SPARCstation is a trademark of SPARC International, Inc.

Solaris and SunOS are trademarks of Sun Microsystems, Inc.

NEWS and NEWS-OS are trademarks of Sony Corporation.

Regional Information

Some information contained in this document may vary from country to country. Before using any NEC product in your application, please contact the NEC office in your country to obtain a list of authorized representatives and distributors. They will verify:

- Device availability
- Ordering information
- Product release schedule
- Availability of related technical literature
- Development environment specifications (for example, specifications for third-party tools and components, host computers, power plugs, AC supply voltages, and so forth)
- Network requirements

In addition, trademarks, registered trademarks, export restrictions, and other legal issues may also vary from country to country.

NEC Electronics Inc. (U.S.)

Santa Clara, California
Tel: 408-588-6000
800-366-9782
Fax: 408-588-6130
800-729-9288

NEC Electronics (Germany) GmbH

Duesseldorf, Germany
Tel: 0211-65 03 02
Fax: 0211-65 03 490

NEC Electronics (UK) Ltd.

Milton Keynes, UK
Tel: 01908-691-133
Fax: 01908-670-290

NEC Electronics Italiana s.r.l.

Milano, Italy
Tel: 02-66 75 41
Fax: 02-66 75 42 99

NEC Electronics (Germany) GmbH

Benelux Office
Eindhoven, The Netherlands
Tel: 040-2445845
Fax: 040-2444580

NEC Electronics (France) S.A.

Velizy-Villacoublay, France
Tel: 01-30-67 58 00
Fax: 01-30-67 58 99

NEC Electronics (France) S.A.

Spain Office
Madrid, Spain
Tel: 91-504-2787
Fax: 91-504-2860

NEC Electronics (Germany) GmbH

Scandinavia Office
Taeby, Sweden
Tel: 08-63 80 820
Fax: 08-63 80 388

NEC Electronics Hong Kong Ltd.

Hong Kong
Tel: 2886-9318
Fax: 2886-9022/9044

NEC Electronics Hong Kong Ltd.

Seoul Branch
Seoul, Korea
Tel: 02-528-0303
Fax: 02-528-4411

NEC Electronics Singapore Pte. Ltd.

United Square, Singapore 1130
Tel: 65-253-8311
Fax: 65-250-3583

NEC Electronics Taiwan Ltd.

Taipei, Taiwan
Tel: 02-2719-2377
Fax: 02-2719-5951

NEC do Brasil S.A.

Electron Devices Division
Rodovia Presidente Dutra, Km 214
07210-902-Guarulhos-SP Brasil
Tel: 55-11-6465-6810
Fax: 55-11-6465-6829

The related documents indicated in this publication may include preliminary versions. However, preliminary versions are not marked as such.

The export of this product from Japan is regulated by the Japanese government. To export this product may be prohibited without governmental license, the need for which must be judged by the customer. The export or re-export of this product from a country other than Japan may also be prohibited without a license from that country. Please call an NEC sales representative.

- **The information in this document is subject to change without notice. Before using this document, please confirm that this is the latest version.**
 - No part of this document may be copied or reproduced in any form or by any means without the prior written consent of NEC Corporation. NEC Corporation assumes no responsibility for any errors which may appear in this document.
 - NEC Corporation does not assume any liability for infringement of patents, copyrights or other intellectual property rights of third parties by or arising from use of a device described herein or any other liability arising from use of such device. No license, either express, implied or otherwise, is granted under any patents, copyrights or other intellectual property rights of NEC Corporation or others.
 - Descriptions of circuits, software, and other related information in this document are provided for illustrative purposes in semiconductor product operation and application examples. The incorporation of these circuits, software, and information in the design of the customer's equipment shall be done under the full responsibility of the customer. NEC Corporation assumes no responsibility for any losses incurred by the customer or third parties arising from the use of these circuits, software, and information.
 - While NEC Corporation has been making continuous effort to enhance the reliability of its semiconductor devices, the possibility of defects cannot be eliminated entirely. To minimize risks of damage or injury to persons or property arising from a defect in an NEC semiconductor device, customers must incorporate sufficient safety measures in its design, such as redundancy, fire-containment, and anti-failure features.
 - NEC devices are classified into the following three quality grades:
"Standard", "Special", and "Specific". The Specific quality grade applies only to devices developed based on a customer designated "quality assurance program" for a specific application. The recommended applications of a device depend on its quality grade, as indicated below. Customers must check the quality grade of each device before using it in a particular application.
 - Standard: Computers, office equipment, communications equipment, test and measurement equipment, audio and visual equipment, home electronic appliances, machine tools, personal electronic equipment and industrial robots
 - Special: Transportation equipment (automobiles, trains, ships, etc.), traffic control systems, anti-disaster systems, anti-crime systems, safety equipment and medical equipment (not specifically designed for life support)
 - Specific: Aircraft, aerospace equipment, submersible repeaters, nuclear reactor control systems, life support systems or medical equipment for life support, etc.
- The quality grade of NEC devices is "Standard" unless otherwise specified in NEC's Data Sheets or Data Books. If customers intend to use NEC devices for applications other than those specified for Standard quality grade, they should contact an NEC sales representative in advance.