

L64781 Single-Chip COFDM Receiver

DVB-T Compliant Demodulation

Overview

The L64781, the second chip in LSI Logic's family of highly integrated, high-performance solutions for digital terrestrial TV broadcast, is a fully integrated, single-chip COFDM (Coded Orthogonal Frequency Division Multiplex) demodulator. The L64781 channel receiver is fully compliant with DVB-T standards and follows the highly successful L64780, widely used by manufacturers producing set-top boxes for the current European digital terrestrial market (OnDigital, Nordig).

Proven Solution for Fast Time to Market

The completeness of this solution enables a spectrum of applications for both 2K-only broadcasting in the UK, and 8K multiple or single frequency network broadcasting in Scandinavia, Spain and other emerging markets such as Singapore. Its robust channel equalizer and doppler immunity also allow manufacturers to use this solution in mobile DVB-T applications.

The L64781 comprises the COFDM demodulator, a DVB-compliant FEC decoder and a 10-bit analog-to-digital converter. With this device, digital set-top box and TV manufacturers have a ready-proven, high-performance technology to bring DTT-enabled products to market quickly and cost effectively.

The L64781 is a fully variable rate demodulator, supporting 6, 7 and 8MHz channels. The chip is highly integrated (both timing and frequency loops are fully digital) and capable of delivering up to 31.7 Mbit/sec. This represents more than 20 movie channels or 4 live video channels in each 8MHz channel previously filled by a single analog PAL channel.



The L64781, LSI Logic's fully integrated single-chip COFDM demodulator, is fully compliant to the DVB-T standard for digital terrestrial television in Europe

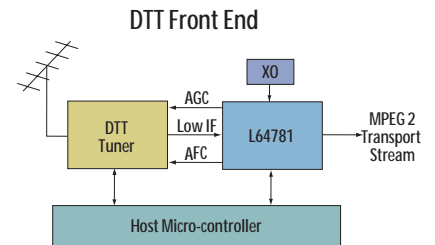

The L64781 interfaces seamlessly to a tuner to provide an error corrected MPEG2-TS. This gives set-top box and TV manufacturers a complete digital terrestrial TV receiver and enables fast time-to-market

L64781 Single-Chip COFDM Receiver

Features

- 2K and 8K FFT size
- Includes FEC and 10-bit ADC
- Digital timing recovery
- 6MHz, 7MHz and 8MHz variable bandwidth capability
- Implements non-hierarchical QPSK, 16-QAM and 64-QAM constellations and hierarchical constellations with scale factors $a = 1, 2$ and 4
- Viterbi code rates 1/2, 2/3, 3/4, 5/6, 7/8
- Guard intervals: 1/4, 1/8, 1/16, 1/32
- Includes digital common phase error correction (CPE)
- Channel state information for protection against multipath and interference
- NIM board with COFDM demodulator, tuner and I2C interface
- Low IF (4.57MHz) sampling with digital baseband down-conversion allowing for single ADC
- Serial microprocessor interface

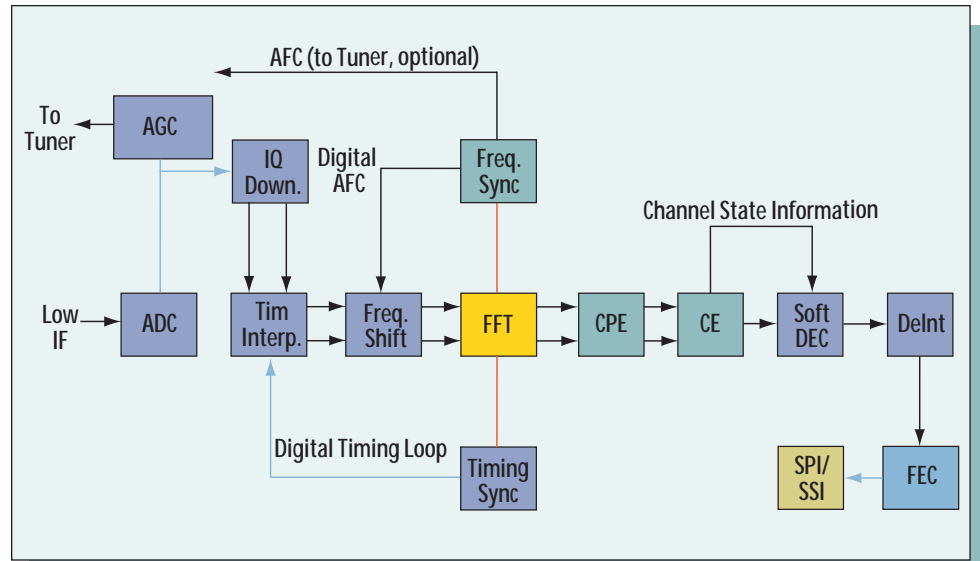

The L64781 applies all error correcting codes to deliver an error-free MPEG2 transport stream to the source decoding chip

Technical Description

The L64781 implements all operational modes specified in the DVB-T specification, i.e., 2K and 8K FFT, non-hierarchical and hierarchical modulations, all guard interval sizes and Viterbi code rates. The chip samples a low IF signal (IF = 4.57 MHz) and converts it digitally into baseband.

The L64781 then applies all digital processing steps to extract the data from the received signal, i.e., FFT, timing and frequency synchronization, channel estimation and equalization, generation of optimal soft decisions using the channel state information, symbol and bit de-interleaving. It also extracts the system information carried by the TPS pilots, stores it into internal registers and delivers it to an external micro controller. The L64781 finally applies all error correcting codes to deliver an error-free MPEG2 transport stream to the source decoding chip.

The L64781 is a highly integrated device that contains both digital timing and frequency loops. No external components are required to operate the demodulation, and only a low cost XO is required. If the tuner requires an analog feedback, the device also provides means for analog timing and frequency control signals in the form of one wire sigma-delta modulated signals. This requires minimal external circuitry and interconnection.

It implements a standard serial micro controller interface.

Complete Solution for Fast Time to Market

To accelerate development of set-top box solutions, the L64781 is available with a developer's kit, allowing manufacturers to select the option best suited to their target market and application requirements. The kit provides the hardware and software components to shorten development cycles and to ensure a fast time to market. The powerful Windows 95 Graphical User Interface allows manufacturers to easily perform validation tests and store results in an intuitive way.



NIM781 Evaluation Board provides full capabilities for accelerated development and fast time to market

The developer's kit consists of a complete evaluation board with a PC interface and MPEG2 transport stream output. Software to enable system testing and code optimization is included, along with a manual that provides test and evaluation information and a PC board layout. It also contains a GUI under Windows 95/97. The NIM781 board also has a seamless interface to LSI Logic's Set-top Box Development Platform.

Components of LSI Logic's L64781 Developer's Kit

- Evaluation board with PC interface and MPEG2-TS output
- Complete documentation
- Software, including driver and GUI interface under Windows
- Board layout
- Schematics
- Bill of materials

Benefits

- Fully integrated single-chip COFDM DVB-T compliant demodulator for fast time-to-market
- Systems expertise and support gained from first-generation chip
- Minimal effort required for implementation in a complete COFDM system
- Rapid time and frequency synchronization
- Excellent mobile reception (channel equalizer handling varying channels)
- Reduced systems costs through common phase error compensation
- Near theory high-performance demodulation algorithm
- Fast access to circuit evaluation with local field application engineering support
- Simple microprocessor interface resulting from high automation

L64781 Single-Chip COFDM Receiver

LSI Logic Integra® Set-top Development Platform

For designers developing a set-top box solution using the L64781 chip, LSI Logic offers the Integra Set-top Development Platform. This provides a complete development environment, including complementary devices, such as the single-chip SC2000 source decoder. It permits designers to implement a complete two-chip set-top box solution.

As an Integra component, the L64781 features all the advantages of this next-generation platform:

- Evolutionary product strategy, ensuring a seamless and cost-effective migration path to the future
- Software compatibility with legacy and new chipsets
- Support for open, international industry standards

Background

The L64780 and L64781 were jointly developed by LSI Logic and the BBC. The BBC, who has been a key influencer in the acceptance of the European DVB-T standard, has implemented hardware prototypes of the COFDM modem and successfully tested it over experimental broadcasts in the UK and other European locations.

In 1998, tests and field trials carried out by the BBC and other validation groups verified performance and interoperability of the new system and highlighted the L64780 as the best performing chipset in the marketplace.

The L64781 has subsequently benefited from various field validations carried out on the L64780, ensuring a high-performance device.

For more information please call:
Europe +32.11.300.351
408.433.7700 Dept. JDS
www.lsilogic.com

LSI Logic Corporation
North American Headquarters
Milpitas, CA
Tel: 1.408.433.8000
Fax: 1.408.433.8989

LSI Logic Europe Ltd
European Headquarters
United Kingdom
Tel: 44.1344.426544
Fax: 44.1344.481039

LSI Logic KK Headquarters
Tokyo, Japan
Tel: 81.3.5463.7821
Fax: 81.3.5463.7820

ISO 9000 Certified

LSI Logic logo design and Integra are registered trademarks of LSI Logic Corporation. All other brand and product names may be trademarks of their respective companies.

LSI Logic Corporation reserves the right to make changes to any products and services herein at any time without notice. LSI Logic does not assume any responsibility or liability arising out of the application or use of any product or service described herein, except as expressly agreed to in writing by LSI Logic; nor does the purchase, lease, or use of a product or service from LSI Logic convey a license under any patent rights, copyrights, trademark rights, or any other of the intellectual property rights of LSI Logic or of third parties.

Copyright ©1999 by LSI Logic Corporation.
All rights reserved.

