

TOSHIBA Bi-CMOS INTEGRATED CIRCUIT SILICON MONOLITHIC

# TD62C805F

## 48BIT THERMAL HEAD DRIVER

The TD62805F is a general purpose 48bit driver IC consisting of 8 block 8bit shift register and 48bit drivers (Open Drain). This device is best suited as a 48 dot thermal printer head drivers.

### FEATURES

- 8bit parallel input and 6 block 8bit shift register
- CMOS compatible input.
- High driverability ..... 30 V / 100 mA / ch
- Built in monostable multivibrator for head protection
- 16 steps gray scale operating with 4bit data
- 48bit open drain outputs
- Package .....  $\mu$ PFP-80 pin

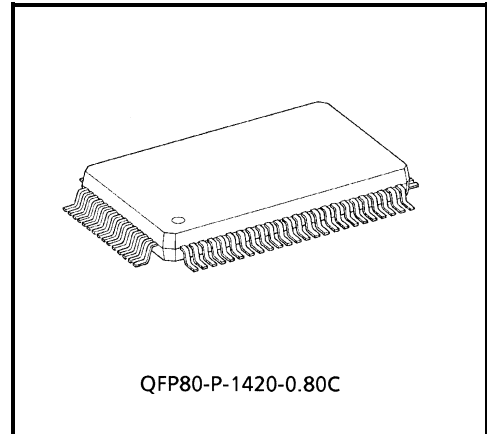

Weight: 1.53 g (Typ.)

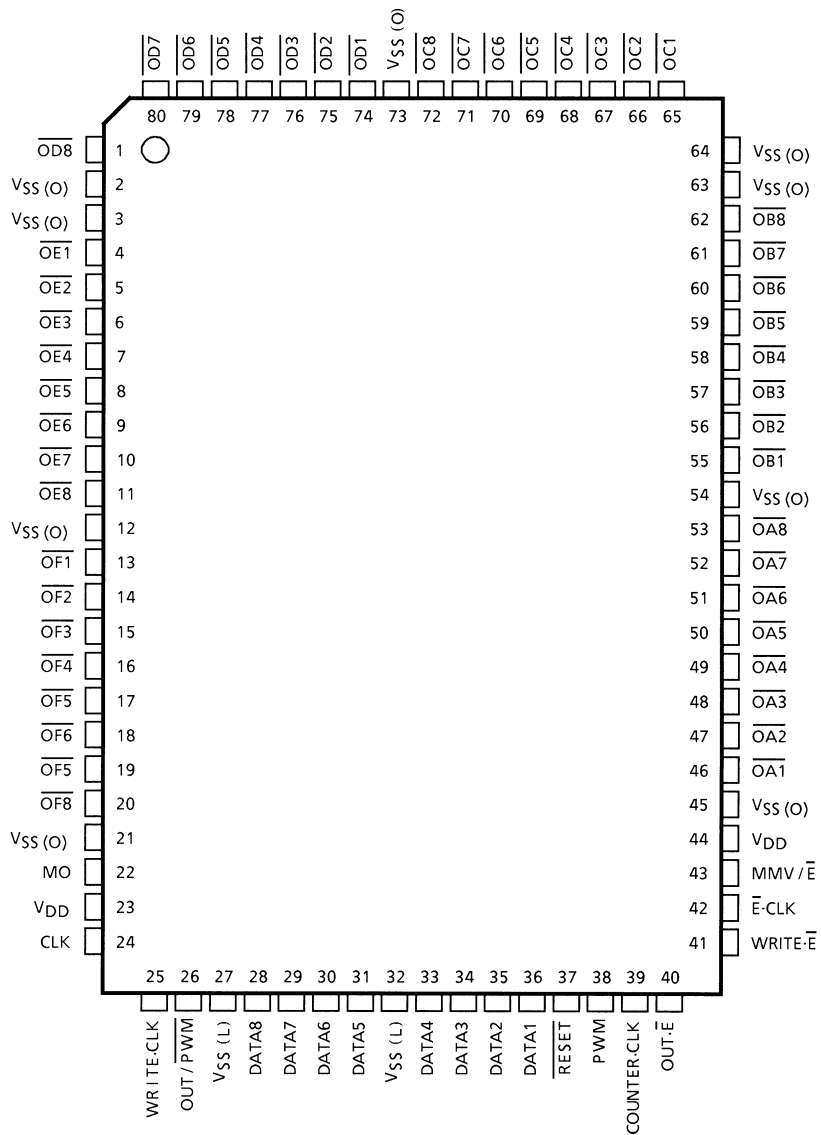

## PIN CONNECTION (TOP VIEW)

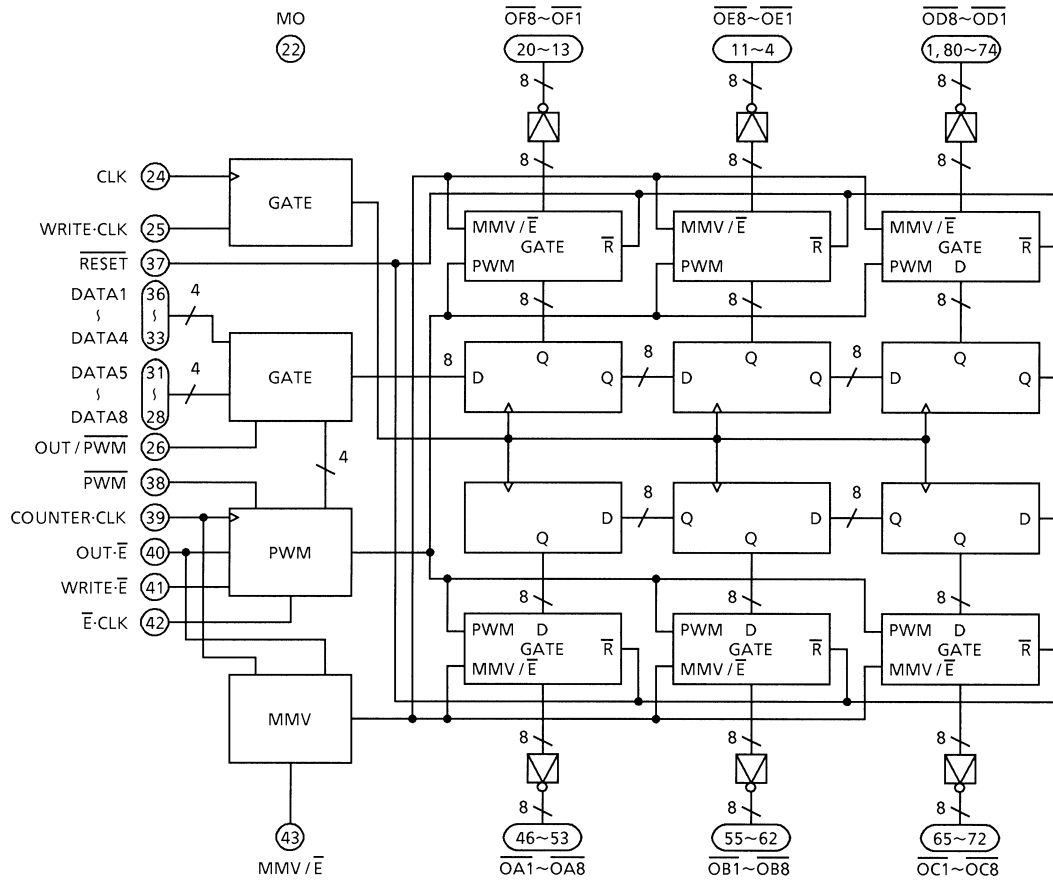

## BLOCK DIAGRAM



## PIN FUNCTION

PIN No.	PIN NAME	FUNCTION
24	CLK	"  ": Data shift
25	WRITE-CLK	"H": enable clock signal, "L": disable clock signal pull-up input terminal
37	$\overline{\text{RESET}}$	"L": all outputs "OFF", reset PWM counter reset PWM counter and MMV circuit Pull-up input terminal
28~36	DATA1~8	Input terminals for output data "H": output "ON", "L": output "OFF" And input terminals for PWM data
26	OUT / $\overline{\text{PWM}}$	"H": enable output data for shift register "L": enable PWM data for counter
38	$\overline{\text{PWM}}$	"L": output enable (PWM operating)
39	COUNTER-CLOCK	Input terminal for clock of PWM counter and for trigger of MMV
40	OUT· $\overline{\text{E}}$	"L": all outputs "ON"
42	$\overline{\text{E}}$ ·CLK	"  ": outputs "OFF" when OUT·E is "High". Outputs "ON" when OUT·E is "Low". Pull-up input terminal
41	WRITE· $\overline{\text{E}}$	"H": enable E-CLK signal pull-up input terminal
43	MMV / E	CR connection terminal for MMV
22	MO	ON / OFF monitor terminal of output $\overline{\text{OF8}}$
23, 44	V <sub>DD</sub>	Supply voltage terminal for control logic
—	V <sub>SS</sub> (O)	GND terminals for driver PIN No. : 2, 3, 12, 21, 45, 54, 63, 64, 73
27, 32	V <sub>SS</sub> (L)	GND terminals for control logic

**(1) Data Input**

D1~D6 of Input Dates are entered to shift Register by the clock signal with the timing of rise.  
 Outputs are latched by holding the WRITE·CLK “Low” or to stop the clock signal.  
 PWM Data (DATA1~4) are latched by OUT / PWM signal “Low”.

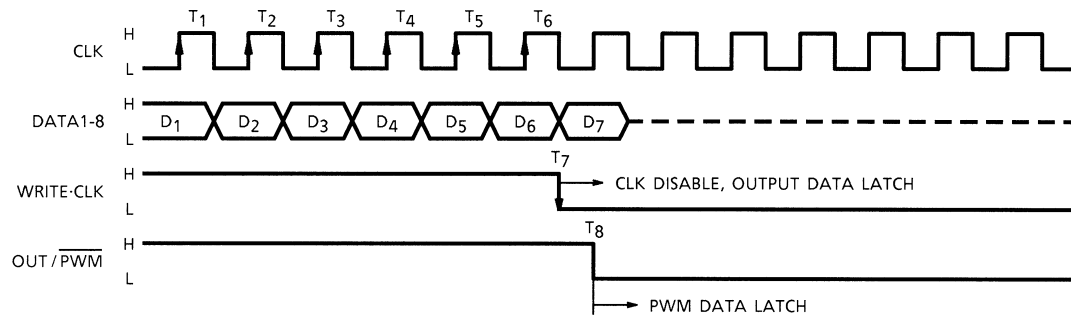

**(2) Output Enable**

Outputs become “OFF” at the first rising edge of E·CLK after the OUT·E to “High”, and become “ON” at the first rising edge of E·CLK after the OUT·E to “Low”.  
 Output ON / OFF duty is controlled by controlling OUT·E signal directly or to change the timing of WRITE·E and E·CLK.

**(3) PWM Control**

Outputs ON / OFF duty are controlled by  $\overline{\text{OUT-E}}$  and PWM DATA of D1~D4 PWM control is performed by comparing the internal 4bit PWM Counter out and PWM DATA of D1~D4.  
 For example, when PWM DATA is 7, 50% Output Duty is obtained.  
 (Refer to tables below.)

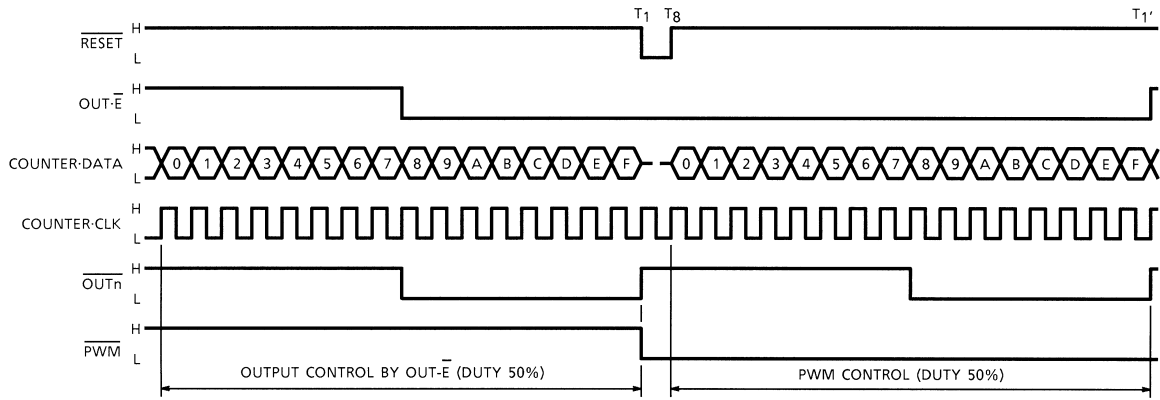

PWM DATA	0	1	2	3	4	5	6	7	8	9
Duty (%)	0	6.25	12.50	18.75	25.00	31.25	37.50	43.75	50.00	56.25

PWM DATA	A	B	C	D	E	F
Duty (%)	62.50	68.75	75.00	81.25	87.50	100.00

**MMV OPERATION**

MMV output of Q becomes “L” when the MMV / E voltage becomes less than  $V_{ref}(L)$  after the first rising edge of INTERNAL CLOCK.

And becomes “H” when the MMV / E voltage above  $V_{ref}(H)$  after re-charging of external capacitance connect to MMV / E. The external capacitance and Resistor connect to MMV / E control MMV Output “ON” period.

So Output Load is protected from burn-out. It's required enough discharging time of external capacitance. (Refer to figure below)

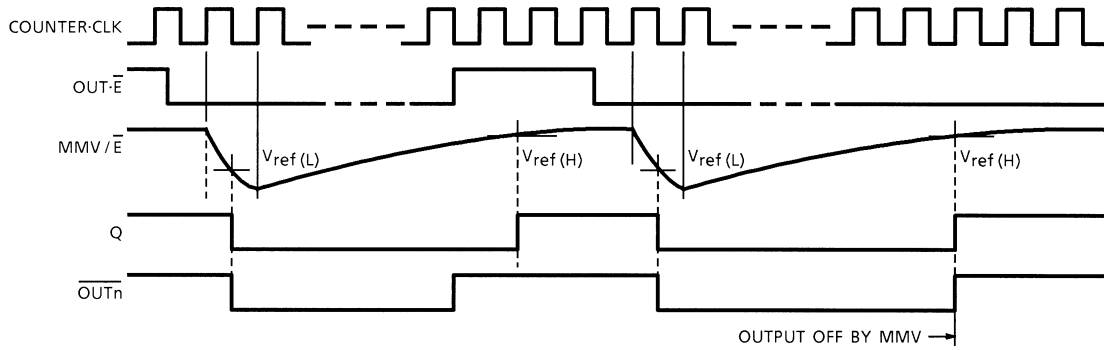

● **Pulse width of MMV**

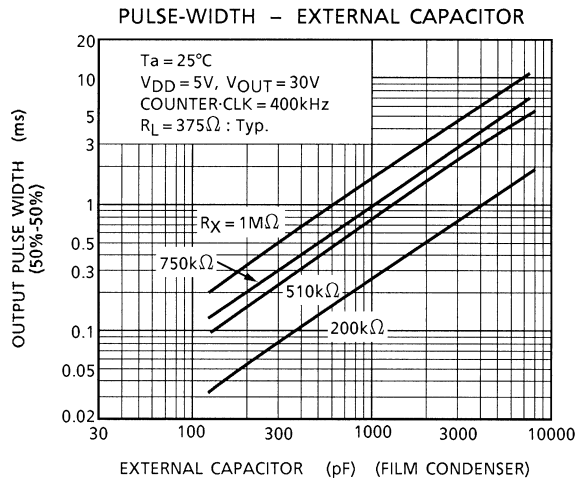

**INPUT CIRCUIT**

**1. DATA1~8, CLK, COUNTER·CLK, OUT /PWM, OUT·E**

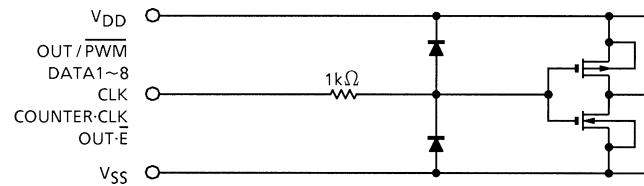

**2. E·CLK, RESET, WRITE·E, WRITE·CLK**

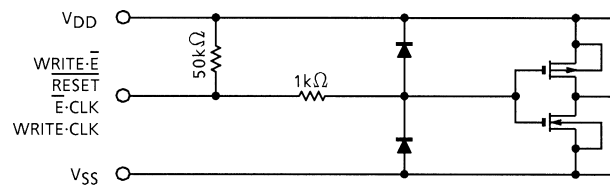

**3. PWM**

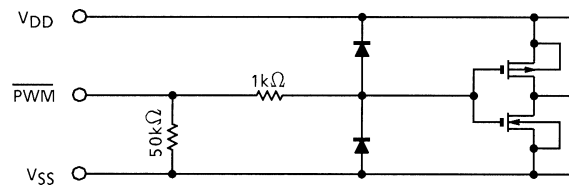

**OUTPUT CIRCUIT**

**1. OA1~8~OF1~8**

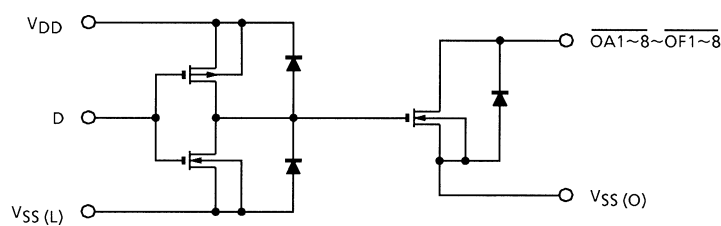



## MAXIMUM RATINGS (Ta = 25°C)

CHARACTERISTIC		SYMBOL	RATING	UNIT
Supply Voltage		V <sub>DD</sub>	7	V
Output Voltage		V <sub>DS</sub>	30	V
Output Current		I <sub>DS</sub>	100	mA / ch
Input Current		I <sub>IN</sub>	±5	mA
Input Voltage		V <sub>IN</sub>	-0.4~V <sub>DD</sub> ±0.4	V
Power Dissipation	Free Air	P <sub>D</sub>	1.0	W
	On PCB (Note)		1.3	
Operating Temperature		T <sub>opr</sub>	-40~85	°C
Storage Temperature		T <sub>stg</sub>	-55~150	°C

Note: On Glass Epoxy PCB (100 × 100 × 1.6 mm, Cu 40%)

## RECOMMENDED OPERATING CONDITIONS (Ta = -40~85°C)

CHARACTERISTIC	SYMBOL	TEST CONDITION	MIN	TYP.	MAX	UNIT
Output Voltage	V <sub>DS</sub>	—	—	—	26	V
Supply Voltage	V <sub>DD</sub>	—	4.5	—	5.5	V
Output Current	I <sub>DS</sub>	Duty 50%	—	—	33.3	mA / ch
		Duty 80%	—	—	26.4	
		Duty 100%	—	—	23.6	
Input Voltage	V <sub>IN</sub>	—	GND	—	V <sub>DD</sub>	V
Operating Clock Frequency	f <sub>CLK</sub>	Duty 50%	—	—	5	MHz
Clock Pulse Width	t <sub>w</sub>	COUNTER·CLK	50	—	—	ns
		CLK				
Data Set-Up Time	t <sub>setup</sub>	—	20	—	—	ns
Data Hold Time	t <sub>hold</sub>					

## ELECTRICAL CHARACTERISTICS (Ta = 25°C, VDD = 5.5 V)

CHARACTERISTIC		SYMBOL	TEST CIR-CUIT	TEST CONDITION	MIN	TYP.	MAX	UNIT	
Input Voltage	"H" Level	V <sub>IH</sub>	—	—	3.5	—	V <sub>DD</sub> + 0.4	V	
	"L" Level	V <sub>IL</sub>	—	—	-0.4	—	1.5		
Input Current	WRITE·CLK E·CLK, RESET WRITE·E	I <sub>INH</sub>	—	V <sub>IN</sub> = 0 V, V <sub>DD</sub> = 5 V	-34	-70	-145	μA	
	PWM	I <sub>INL</sub>	—	V <sub>IN</sub> = 5 V, V <sub>DD</sub> = 5 V	34	70	145		
Output Voltage		V <sub>DS</sub>	—	OA1~OF8	I <sub>DS</sub> = 80 mA	—	—	960	mV
					I <sub>DS</sub> = 50 mA	—	—	600	
Output On Resistor		R <sub>ON</sub>	—	I <sub>DS</sub> = 50 mA	—	—	12.0	Ω	
Output Leak Current		I <sub>OZ</sub>	—	V <sub>DS</sub> = 30 V	—	—	10	μA	
Quiescent Current		I <sub>DD</sub>	—	—	—	—	20	μA	
Operating Supply Current		I <sub>DDopr</sub>	—	V <sub>DD</sub> = 5 V, f <sub>CLK</sub> = 5MHz Output OPEN	—	—	5	μA	

## SWITCHING CHARACTERISTICS (V<sub>DD</sub> = 5.5 V, V<sub>DS</sub> = 26 V, Ta = 25°C)

CHARACTERISTIC		SYMBOL	TEST CONDITION	MIN	TYP.	MAX	UNIT
Maximum Operating Clock Frequency		f <sub>MAX</sub>	Duty 50%	10	—	—	MHz
Propagation Delay Time "L"→"H"	CLK- $\overline{\text{OUTn}}$ , WRITE·CLK- $\overline{\text{OUTn}}$	t <sub>pLH</sub>	Duty 50% V <sub>IN</sub> (H) = 4.5 V V <sub>IN</sub> (L) = 0 V R <sub>L</sub> = 375 Ω C <sub>L</sub> = 15 pF	—	80	—	ns
	RESET- $\overline{\text{OUTn}}$			—	100	—	
	COUNTER, CLK- $\overline{\text{OUTn}}$ (Note)			—	110	—	
	OUT· $\overline{\text{E}}$ - $\overline{\text{OUTn}}$ , WRITE· $\overline{\text{E}}$ - $\overline{\text{OUTn}}$ $\overline{\text{E}}$ -CLK- $\overline{\text{OUTn}}$			—	100	—	
	MMV/ $\overline{\text{E}}$ - $\overline{\text{OUTn}}$			—	130	—	
Propagation Delay Time "H"→"L"	CLK- $\overline{\text{OUTn}}$ , WRITE·CLK- $\overline{\text{OUTn}}$	t <sub>pHL</sub>		—	60	—	
	RESET- $\overline{\text{OUTn}}$			—	100	—	
	COUNTER, CLK- $\overline{\text{OUTn}}$ (Note)			—	90	—	
	OUT· $\overline{\text{E}}$ - $\overline{\text{OUTn}}$ , WRITE· $\overline{\text{E}}$ - $\overline{\text{OUTn}}$ $\overline{\text{E}}$ -CLK- $\overline{\text{OUTn}}$			—	70	—	
	MMV/ $\overline{\text{E}}$ - $\overline{\text{OUTn}}$			—	80	—	
Minimum Clock Pulse Width		t <sub>w</sub>		25		—	
Data Set Up Time	DATA-OUT / PWM	t <sub>setup</sub>	—	—	10	—	
	DATA-CLK						
	OUT· $\overline{\text{E}}$ - $\overline{\text{E}}$ -CLK						
Data Hold Time	DATA-OUT / PWM	t <sub>hold</sub>	—	—	10	—	
	DATA-CLK						
	OUT· $\overline{\text{E}}$ - $\overline{\text{E}}$ -CLK						
Maximum Rise Time	COUNTER-CLK	t <sub>r</sub>	—	—	—	1	μs
	CLK						
Maximum Fall Time	COUNTER-CLK	t <sub>f</sub>	—	—	—	1	
	CLK						
Output Rise Time	$\overline{\text{OUTn}}$	t <sub>or</sub>	—	0.02	—	1	
Output Fall Time		t <sub>of</sub>	—	0.05	—	0.4	
MMV Pulse Width		t <sub>MMV</sub>	—	—	3	—	ms

Note: COUNTER DATA = F

## PRECAUTIONS for USING

This IC does not integrate protection circuits such as overcurrent and overvoltage protectors.

Thus, if excess current or voltage is applied to the IC, the IC may be damaged. Please design the IC so that excess current or voltage will not be applied to the IC.

Utmost care is necessary in the design of the output line, VCC and GND line since IC may be destroyed due to short-circuit between outputs, air contamination fault, or fault by improper grounding.



**RESTRICTIONS ON PRODUCT USE**

000707EBA

- TOSHIBA is continually working to improve the quality and reliability of its products. Nevertheless, semiconductor devices in general can malfunction or fail due to their inherent electrical sensitivity and vulnerability to physical stress. It is the responsibility of the buyer, when utilizing TOSHIBA products, to comply with the standards of safety in making a safe design for the entire system, and to avoid situations in which a malfunction or failure of such TOSHIBA products could cause loss of human life, bodily injury or damage to property.  
In developing your designs, please ensure that TOSHIBA products are used within specified operating ranges as set forth in the most recent TOSHIBA products specifications. Also, please keep in mind the precautions and conditions set forth in the "Handling Guide for Semiconductor Devices," or "TOSHIBA Semiconductor Reliability Handbook" etc..
- The TOSHIBA products listed in this document are intended for usage in general electronics applications (computer, personal equipment, office equipment, measuring equipment, industrial robotics, domestic appliances, etc.). These TOSHIBA products are neither intended nor warranted for usage in equipment that requires extraordinarily high quality and/or reliability or a malfunction or failure of which may cause loss of human life or bodily injury ("Unintended Usage"). Unintended Usage include atomic energy control instruments, airplane or spaceship instruments, transportation instruments, traffic signal instruments, combustion control instruments, medical instruments, all types of safety devices, etc.. Unintended Usage of TOSHIBA products listed in this document shall be made at the customer's own risk.
- The products described in this document are subject to the foreign exchange and foreign trade laws.
- The information contained herein is presented only as a guide for the applications of our products. No responsibility is assumed by TOSHIBA CORPORATION for any infringements of intellectual property or other rights of the third parties which may result from its use. No license is granted by implication or otherwise under any intellectual property or other rights of TOSHIBA CORPORATION or others.
- The information contained herein is subject to change without notice.